

KOBELT

ELECTRONIC CONTROLS
HYDRAULIC STEERING & ACCESSORIES
PNEUMATIC CONTROLS
PUSH-PULL CONTROLS
DISC BRAKES

FOR THE LATEST INFORMATION
PLEASE VISIT www.KOBELT.com

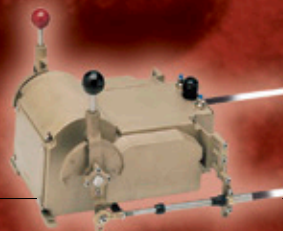

CONTROL YOUR SHIP WITH COMPLETE SYSTEMS AND COMPONENTS FROM KOBELT MANUFACTURING

- 1 Steering components up to 320 tonmeter for hydraulic steering of single and multi-rudder vessels
- 2 In the aftdeck control station, complete control over all propulsion and deck machinery.
- 3 Hydraulic cylinders and control devices for lowering and raising masts, davits for lifeboats, loading ramps etc.
- 4 Weatherproof controls for outside stations to control propulsion and deck machinery.
- 5 Control components for propulsion and deck machinery, plus electronic alarm systems and electronic telegraphs.
- 6 Control for all deck machinery such as anchor and towing winches.
- 7 Controls for bow thrusters.
- 8 Control components for any propulsion package, fixed pitch CP propellers, load share and load control.
- 9 Propeller shaft disk brakes, from small engines up to 50,000 HP.
- 10 Control components to control stern thrusters.



KOBELT ELECTRONIC CONTROLS

OUR HISTORY RUNS DEEP

Ever since our humble beginnings in 1962, Kobelt Manufacturing Limited has been committed to manufacturing the finest marine controls in the world. From our very first line of pneumatic controls, we've believed in the simple things – rugged construction, quality materials and prompt delivery to our customers. Today, the technology has changed, but our commitment remains the same. From our innovations in electronic controls to our craftsmanship with bronze and stainless steel, our products span the oceans of the world to further our reputation as an international leader in maritime technology.

KOBELT ELECTRONIC CONTROL COMPONENTS

- Motorola microprocessor with a LAN input for head units.
- Up to twelve point switch inputs for the synchronizer and alarms.
- Eight point potentiometer input for the actuator feedback.
- Six actuator outputs.
- Two brake relays.
- Alarm relay.
- RS232 communication port to ensure communication and calibration of all components of the control system.

QUALITY MATERIALS

To ensure many years of corrosion-free operation, all Kobelt control components are made of bronze and stainless steel. Look closely and you'll see we even use bronze to house such things as microprocessors and PC boards. It may take a little more effort to build, but it assures us that we're supplying you with nothing but the very best.

BUILT TO ORDER

From the simplest manual hydraulic steering gear to the most sophisticated electrohydraulic steering systems for



ocean-going vessels, Kobelt can custom manufacture to meet your exact needs. Our line of propulsion products, control components and steering gear is the most comprehensive in the world. If there's something you need that's not in this brochure, we probably have it! Just give us a call.



All Kobelt Manufacturing products featured in this catalogue are European Common Community approved or designated for approval.

FUNCTIONS

- Electronic or mechanical throttle outputs
- Electric or mechanical clutch output
- Constant and variable timing
- Throttle boost
- Clutch delay
- Overriding throttle
- CP propeller control
- Shaft brake timing
- Engine load control
- Station outlook
- Engine synchronizer
- Trolling valve
- Engine alarms
- Omega slip clutch
- Control monitoring
- PTO control

POWERING KOBELT ELECTRONIC CONTROLS

Clean 12 or 24 volt power is required along with sufficient amperage and voltage. A single cable connects the control heads and the CPU.



ELECTRONIC SYSTEM SELECTION GUIDE

We offer 3 major systems to meet your needs. The simplest (best buy) is the Mighty Mariner. If it meets your current and future needs, we recommend using that. If you have a complex system, then we offer the 6525 system. If you have a 360° system (right-angle drive or Z-drive), contact us for details about the 6535 system.

MIGHTY MARINER

- Up to 4 control stations
- 40 meter total¹ length for communication cables
- Operate 1, 2 or 3 engines
- Interface with Engine and Clutch should be either:
 - All mechanical
 - All electronic/electric

For mixed interfaces (mechanical and electronic):

- Mechanical clutch signal can be turned into electric signal with 2170
- Mechanical throttle signal can be turned into electronic signal only on certain engines.

Mighty Mariner has many features and options. It can work with various control heads:

- 6505S is the normal small control head
- 6555 is the normal large control head²
- 6527-S is the normal actuator
- 7176 walk-about control can be used²
- 6506 side-mount control can be used²

This system requires a 24 Volt power supply. We carry converters if you require them.

6525 SYSTEM

- Up to 8 control stations
- 1, 2 or 3 engines
- Any combination of mechanical or electric interfaces for the engine and clutch
- Longer cable runs
- Trolling valve option
- Good for water jets and controllable pitch systems
- Can integrate with steering systems
- Has the widest variety of control heads available

¹ All cable lengths added together must be under 40 meters (130 feet)

² Requires a 6505-2000 panel

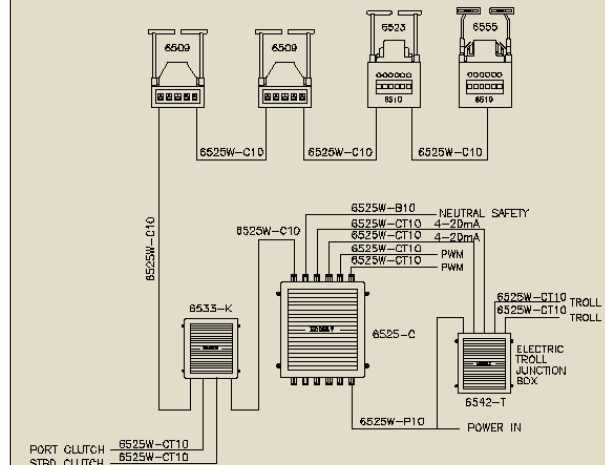
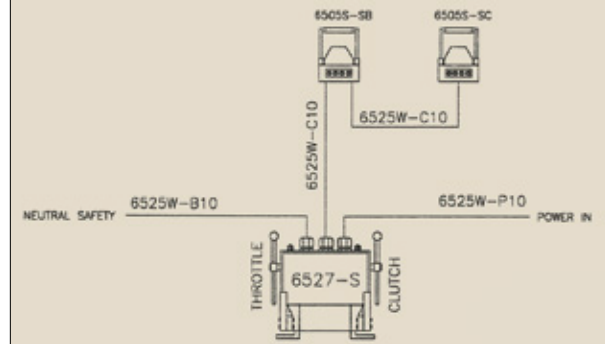

KOBELT MANUFACTURING ELECTRONIC CONTROLS PRELIMINARY PROPOSAL WORKSHEET

PROVIDE AS MUCH INFORMATION AS POSSIBLE

CUSTOMER: _____

Vessel length: _____ Hull Type _____

Type: _____ Max Speed: _____

Number of Engines: _____

Engine Make: _____ Engine HP _____

Engine Model: _____ Engine RPM _____

- Governor Type: Mechanical Electronic
 If electronic, signal required: PWM 0-5 Volt 4.20mA Other
 If other, please specify _____
- Gear Box Make: _____ Gear Box Model: _____
 Gear Box Control: Mechanical or Electric Solenoid _____
- Trolling Valve: Yes No If Yes, Mechanical or Electronic _____
 If Electronic please specify signal requirement _____
- CPP (Controllable Pitch Propeller): Yes No Split Levers or Combined _____
 If yes mechanical or electric control
 If combined is automatic pitch – trim required Yes No
 If yes specify type of control signal required _____
- Bow Thruster Yes No On/Off or Proportional _____
 If Proportional specify type of control signal required _____
- Stern Thruster Yes No On/Off or Proportional _____
 If Proportional specify type of control signal required _____
 Engine Synchronization Yes No
 If yes, Engine Manufacturer or Kobelt Supplied _____

Number of Control Stations and Control Head Choice if known, if not we will recommend best suited for application

Station/Location:	Control Head Model:	Panel Type: (if applicable)
i.e. (1, Wheelhouse)	6555-B	6510-S6)

Classification required: Yes No Classification type: _____ (i.e. ABS, BV, Lloyd's, etc.)

THE MIGHTY MARINER – MECHANICAL

The system is comprised of the basic 6505S control head in combination with the 6527-S electronic actuator, both in sturdy bronze and stainless steel.

The control head is completely watertight from the topside* and can be used in any location on board. The 6527-S actuator is a stand-alone actuator† with manual override. The electronics are stored in the housing of the actuator itself, eliminating the need for a separate microprocessor unit. This simplified control system is perfectly suited for most boats, and has all the extra safety features found exclusively at Kobelt.

The Mighty Mariner is designed for Do-it-yourself installation. Communication is via a CAN Bus. This system offers up to 4 stations with station interface, station lock, overriding throttle and synchronization*.

* The bottom is not watertight and must be protected from the environment.

† Can only be used for clutch and throttle functions.

★ Synchronizer kit is extra.

Choose The Mighty Mariner That's Right For Your Vessel

- Features:
- Self monitoring
 - System temperature monitoring
 - Clutch and throttle delay
 - Neutral safety
 - Station lock
 - Wire break monitoring
 - Potentiometer monitoring
 - Overriding throttle
 - Engine synchronization

Mighty Mariner Configurations:

- | | Part # |
|--------------------------------|-----------------|
| • Single Engine One Station | – Model 6500-S1 |
| • Single Engine Two Stations | – Model 6500-S2 |
| • Single Engine Three Stations | – Model 6500-S3 |
| • Single Engine Four Stations | – Model 6500-S4 |
| • Twin Engine One Station | – Model 6500-T1 |
| • Twin Engine Two Stations | – Model 6500-T2 |
| • Twin Engine Three Stations | – Model 6500-T3 |
| • Twin Engine Four Stations | – Model 6500-T4 |

Please specify colour of control heads at time of order.

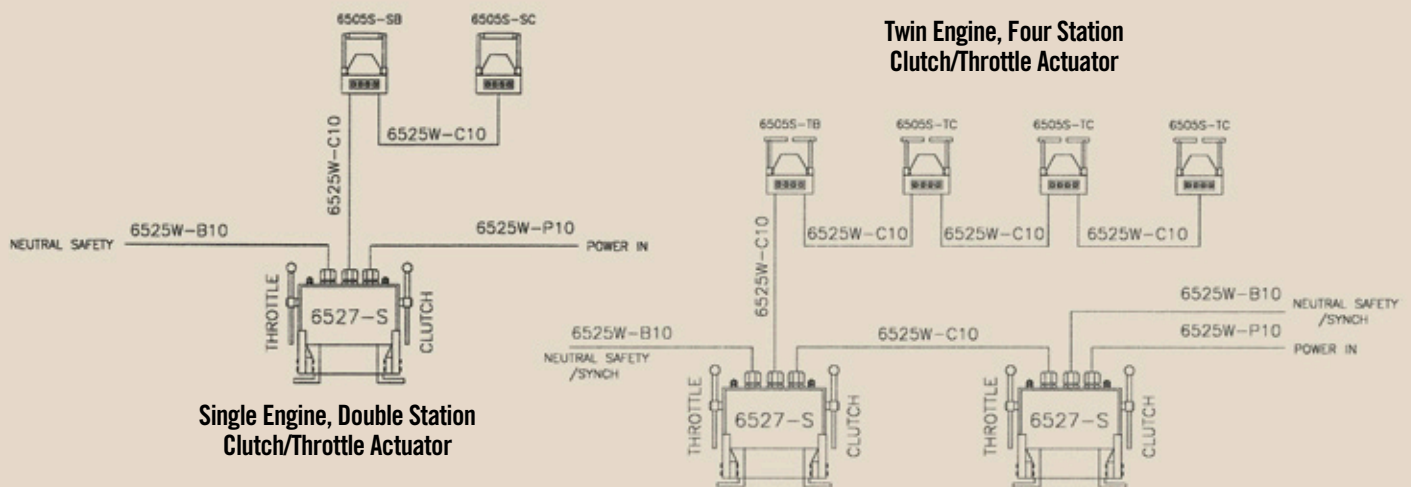
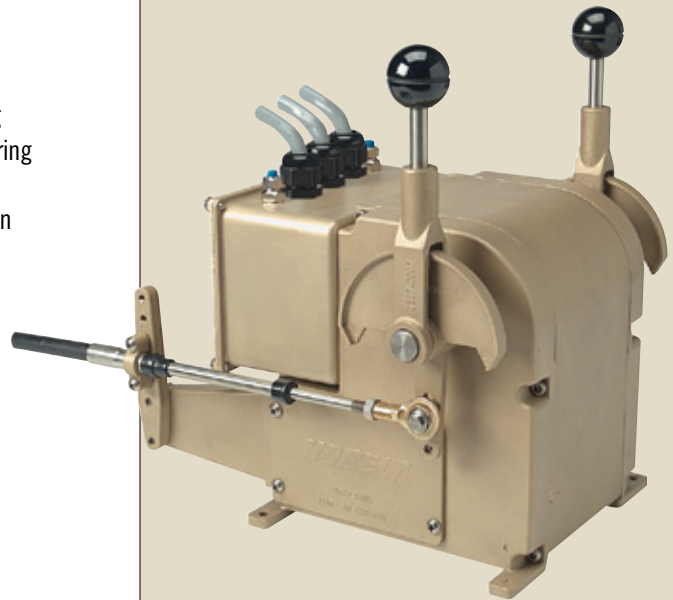

The Mighty Mariner system can be used with Electronic Clutch and Throttle interfaces.

The control heads are the same. However, a model 6503 processor is used to:

- Monitor all the input information from control heads and switch panels
- Communicate to the control heads and sonalerts
- Operate a clutch solenoid
- Operate the throttle signal for the engine

The 6505-2000 remote selector panel (shown on right) extends the range of products that can be used with the Mighty Mariner system. This remote panel has all the basic functions available on a 6505S control station and is suitable for inside or outside installations.

The control heads that can be used now include:

- 6506 Side-mount control
- 6555 Illuminated control
- 7176 Walk-about control
- and various other controls including joysticks

The drawing shown below is for a single engine, two station system. You can get systems for one or two engines, and from one to four stations.

There is more literature on our website: www.Kobel.com

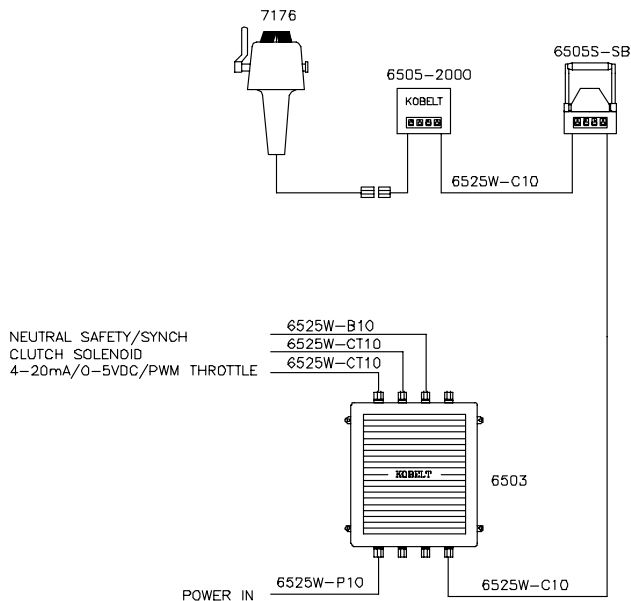

**6505S
Control Head**

Shown in single engine configuration



**6505-2000
Remote Panel**



**6503
Electronic Interface**

6525 MODEL MICROPROCESSOR

Weight 15.5 lbs (7 kg)

This state-of-the-art digital central processor unit accepts up to 8 control stations with only two communicating wires and can control two main propulsion engines and their respective reverse gears or CP propellers. The 6525 also inputs the control of trolling valves and provides all interlocking for regular propulsion systems, including propeller shaft brakes and throttle boosts.

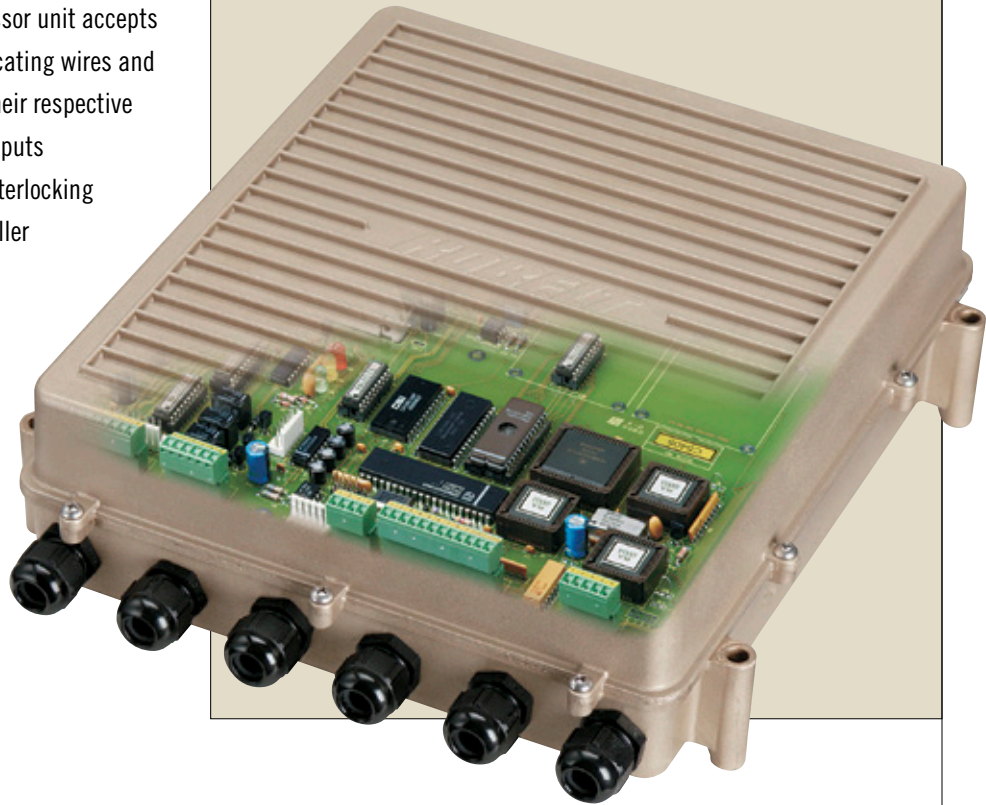

The 6525 is the most flexible system and works with all our components.



6504



6508



6525



6506



6512



6514

See our website to get exact dimension details. This unit is approximately 12" x 12" x 4".

6501 ILLUMINATED ELECTRONIC CONTROL HEAD

The 6501 is the illuminated version of the 6505 control head which offers not only compact design but the features of a full size control. Where space and visibility are limited, this is the head of choice. The keypad offers switches for the standard features: Station Select, Station Lock, Throttle Override and Synchronization. Incorporation of the latest electronic technology allows this head to team up with any of the Kobelt control systems.

The housing and handles are manufactured in bronze and stainless steel. The unit uses a water resistant keypad but is not completely waterproof.

The standard head comes without base but with potentiometers.

Ordering Options:

No. Engines: Single or Twin

Finish: Chrome, Black or White Epoxy, Polished Bronze

Handle: Standard, plastic grip or 'Elegant' style

No. Potentiometer: 1 or 2

Panel Keypad: 4 Switches

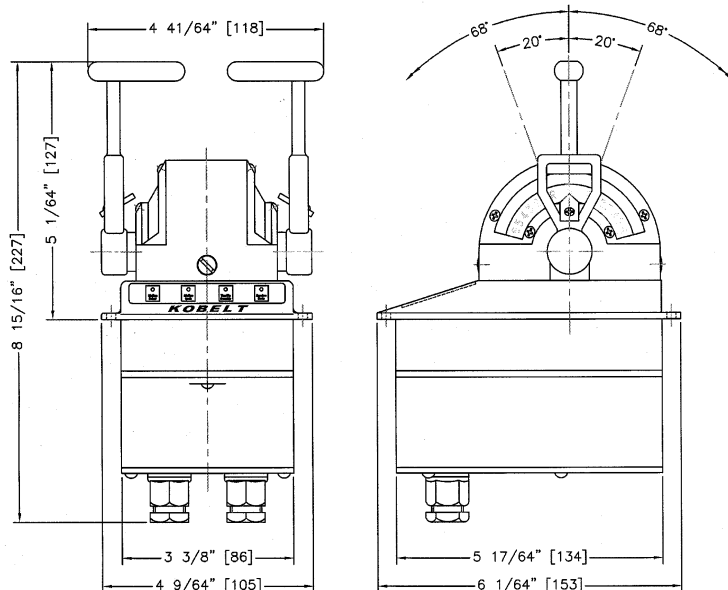

6501-ATC
control head with optional panel base



6501-TC-E
control head - elegant style

6504 CONTROL HEAD

The 6504 control head provides precision and reliability. This product is intended for the sleek pleasure craft market. It integrates with all other components of the 6525 system. It is constructed entirely of bronze and stainless steel and will give many years of trouble-free service. It is also possible for this control head (and all control heads of the 6525 system) to incorporate other functions such as Steering and Thruster controls, providing the operator with a complete control package.

Weight 9 lbs (4.2 kg)



6505 CONTROL HEAD

Weight 7 lbs (3 kg)



This unit has a compact design yet offers all of the features and accuracy of our larger models. The control housing (except electronic components) is constructed in bronze and stainless steel. The standard unit is available in chrome, black or white epoxy. This unit is totally water tight from the topside and can be used anywhere on board. The bottom side must be protected from the elements. The 6505S includes a microprocessor that is used exclusively with the Mighty Mariner system.

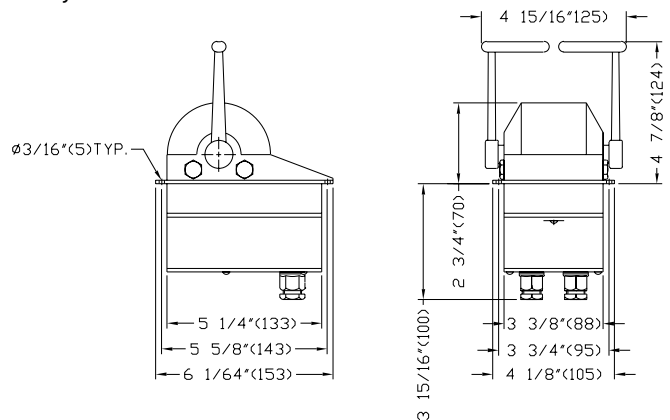

6506 SIDE MOUNT

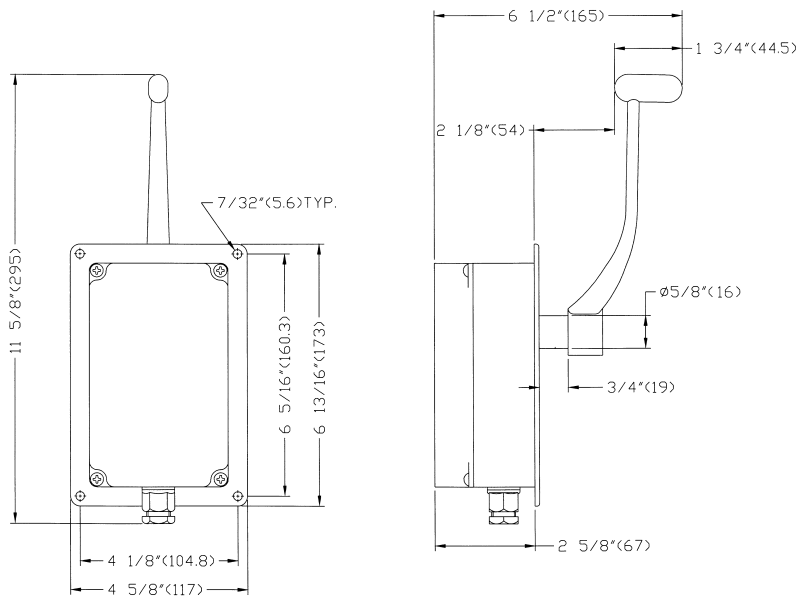

Weight 6.6 lbs (3 kg)



The 6506 is a side mounting electronic control, ideal for single lever clutch & throttle or any combination of CP propeller and trolling valve applications. The chrome-finished handle is attached to the control on a 36-tooth spline for 10° increment adjustments. The unit can be installed either externally or internally and is equipped with adjustable friction and detent. As an added fail-safe measure, it can also be equipped with two potentiometers. The 6506 requires an external headboard (model 6507) and is compatible with all other Kobelt control devices.

6507 MODE SELECTOR

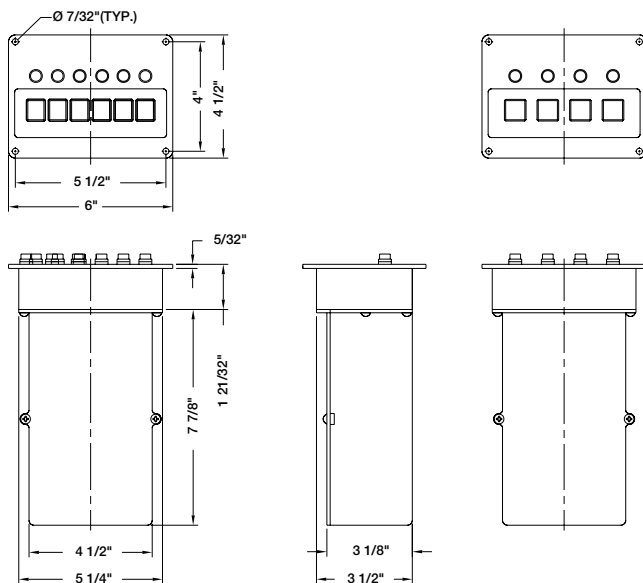

Weight 5.5 lbs (2.5 kg)



This unit was developed for vessels that have a control station and mode selector located in different areas. This is especially useful for sport-fishing boats that have two side mount controls installed on the aft console and the mode selector mounted on top. It is constructed entirely in bronze and is waterproof from the top side. Available with either four or six selector buttons and indicator lights.

Options

- 6507-S4 4 Switches & lights
- 6507-S6 6 Switches & lights
- Available in Black epoxy (as shown)
- Polished Bronze
- Chrome Plated

6508 ILLUMINATED CONTROL HEAD

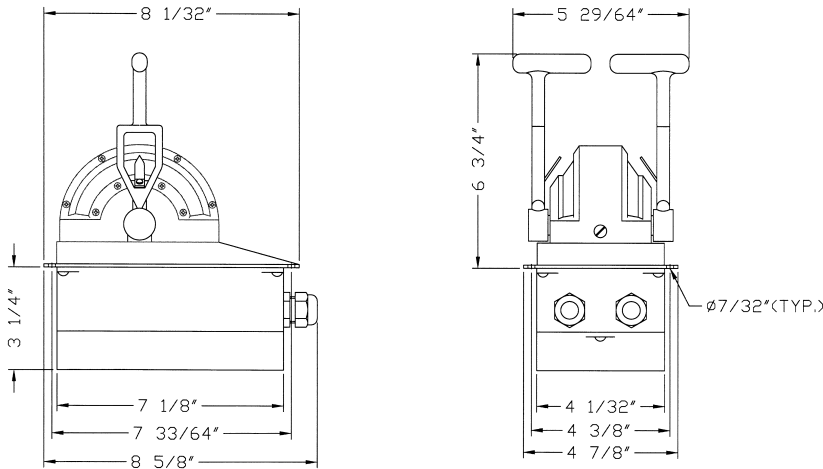

Weight 9.9 lbs (4.5 kg)



Available with a 5 switch keypad for trolling or CPP applications.

The 6508 Control Head is constructed from bronze and stainless steel and has the same mounting and cutout as our popular 6509 model. However, because the 6508 is illuminated, it is recommended for interior use only. At an extra cost, the 6508 can be equipped with two potentiometers per handle to act as a fail-safe measure. With this option, our microprocessor is able to read both potentiometers at all times. Should the microprocessor receive a faulty signal from one of the potentiometers, it will emit an alarm to inform the operator of a problem.

Options:
Black Epoxy
Chrome Plate

6509 INTEGRATED ELECTRONIC CONTROL HEAD

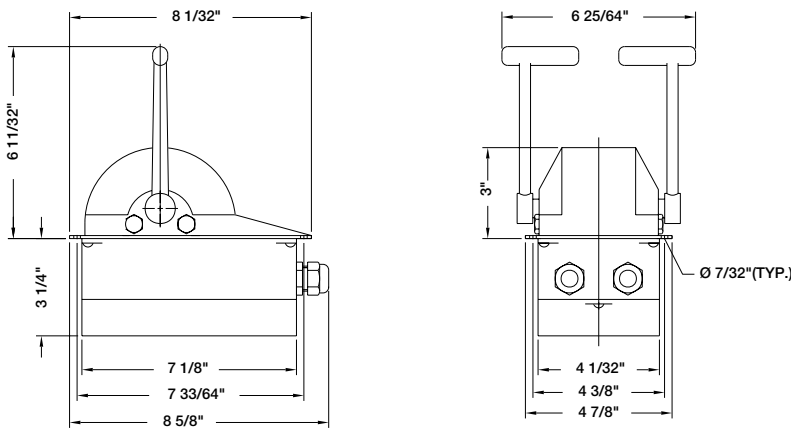

Weight 8.8 lbs (4 kg)



Available with a 5 switch keypad for trolling or CPP applications.

Small and water-tight, this bronze and stainless steel control head can be installed into practically any small space, anywhere on board ship. The low-profile illuminated key pad has four standard switches for Station Select, Station Lock, Overriding Throttle and Engine Synchronization. For fixed propulsion applications, non-illuminated side scales can be attached to the control head. Options such as single engine configuration and trolling valve compatibility, plus a two year limited warranty has made this model one of our most popular control heads.

6510 CONTROL BASE

This state-of-the-art unit was especially designed for the discriminating boat owner who demands both durability and reliability. The 6510 is compatible with most Kobelt electronic control heads, allowing you to configure the control head to virtually any combination. The LED indicator light and sleek polyester buttons are user friendly and give the control head a look that ties into any wheelhouse decor.

6510 base works with your choice of the following control heads:

- 6515
- 6523
- 6545
- 6555

Ordering Options:

- 6510-S4 4 Switches
- 6510-S6 6 Switches

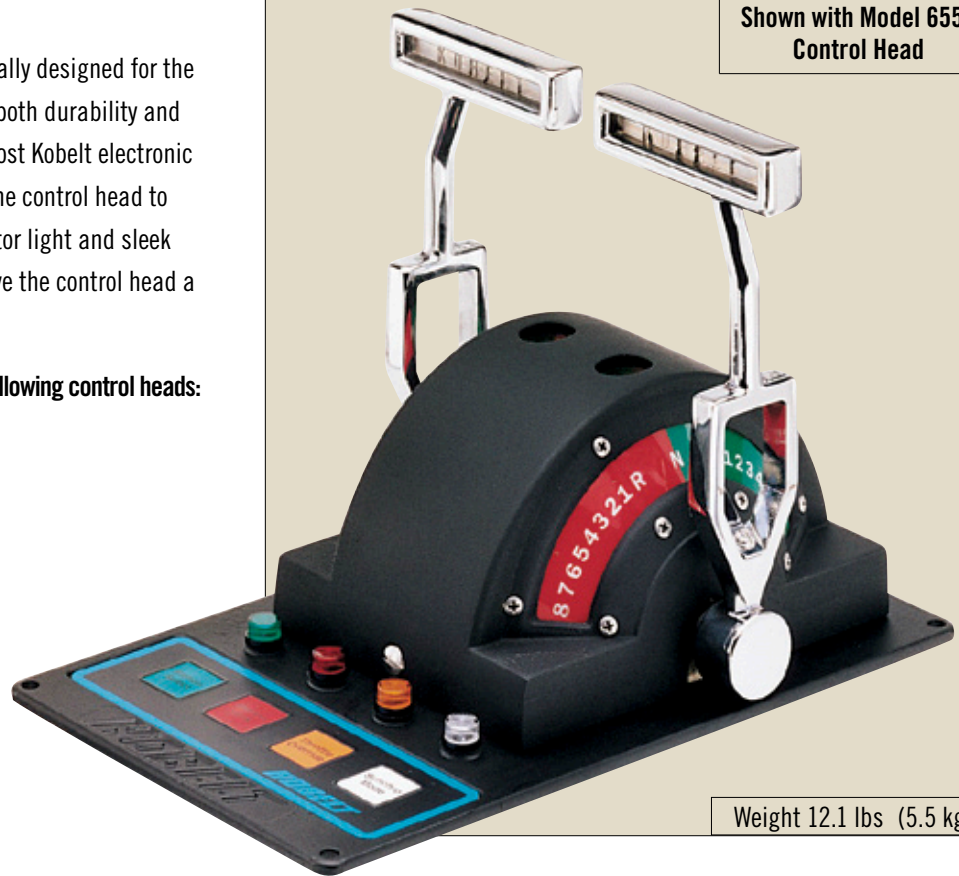

Shown with Model 6555 Control Head

Weight 12.1 lbs (5.5 kg)

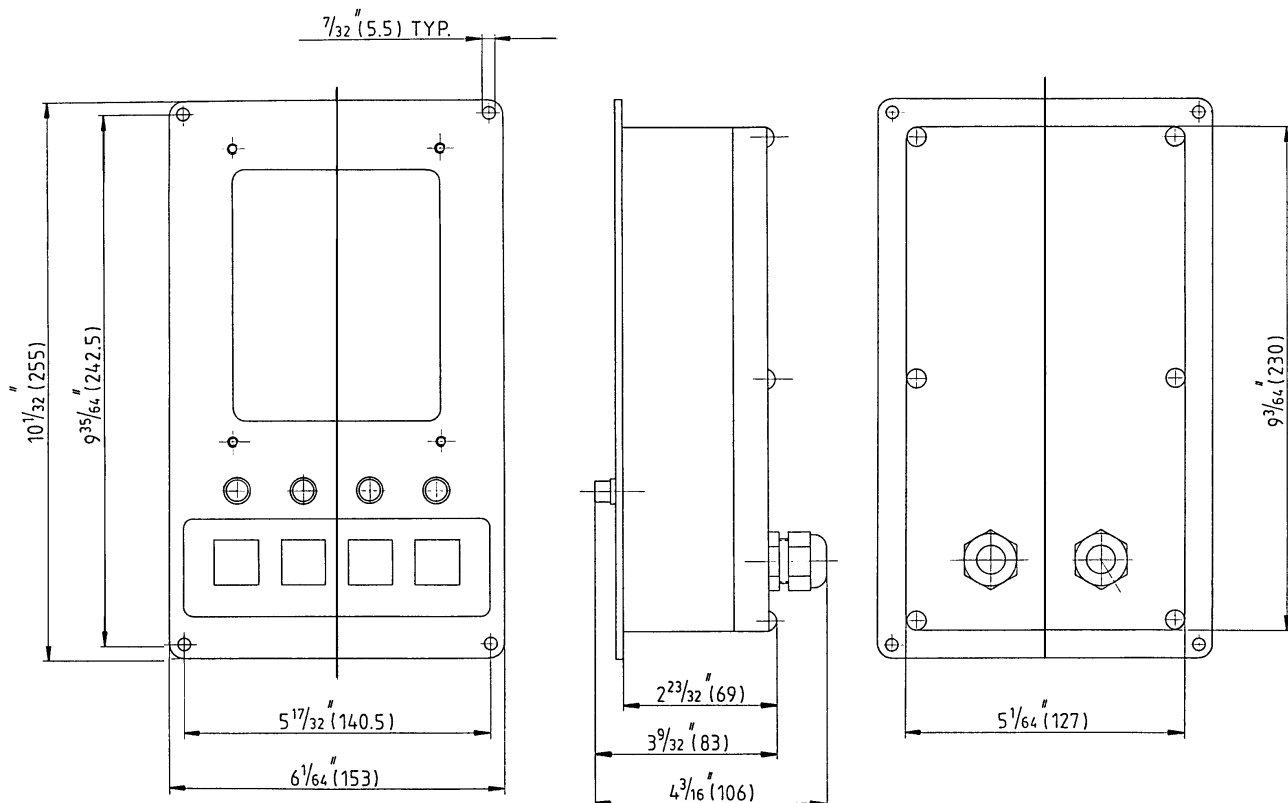

6511 CONTROL BASE

From the North Atlantic to the South Pacific, Kobelt interior and exterior control heads are known worldwide for their craftsmanship and durability. All our electronic controls are constructed from bronze and stainless steel and are available in both twin and single engine configurations. And whether you prefer black epoxy, chrome or polished brass, we've got a housing finish to suit any wheelhouse decor. For those with a taste for the opulent, we can even have them gold-plated!

If you need a control head to handle various functions such as trolling modes and overriding throttle, just give us the details and we can custom build one to suit your needs.

Order Options:

- B = Black Epoxy
- C = Chrome
- D = Polish Bronze
- E = Base Plate

6511 base works with your choice of the following control heads:

- 6515 6545
- 6523 6555

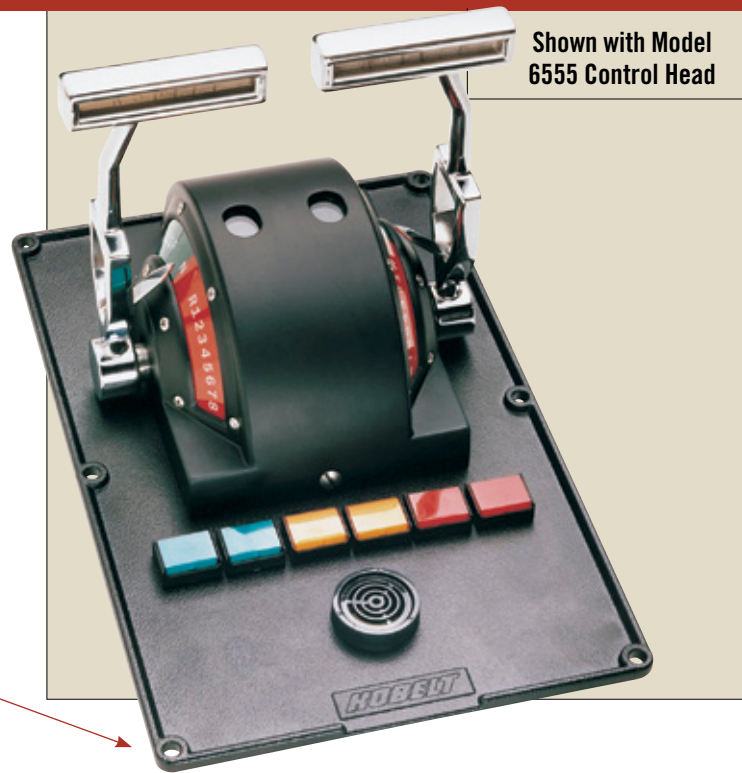

Shown with Model 6555 Control Head

6512 CONTROL BASE

Weight 20 lbs (9 kg)

Shown with Model 6555 Control Head

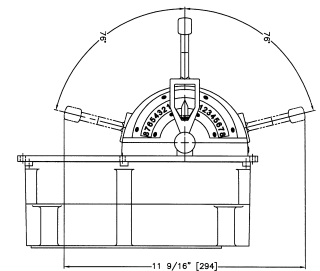
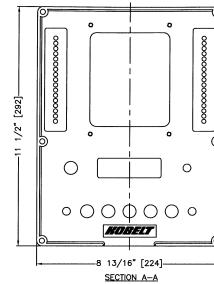
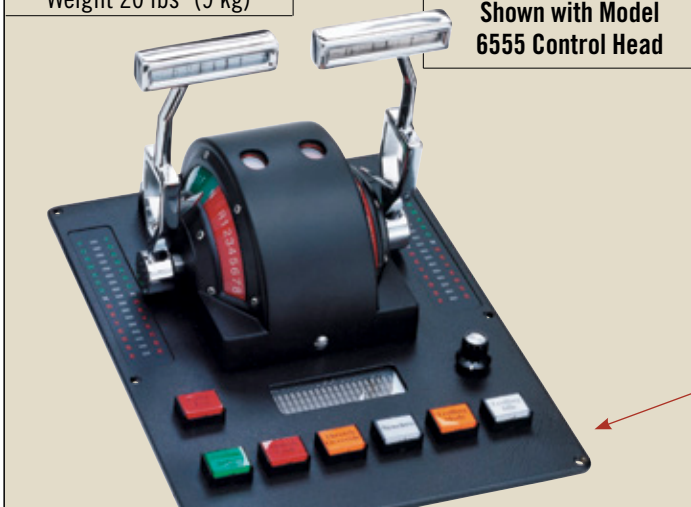

6512 base works with your choice of the following control heads:

- 6515 6545
- 6523 6555

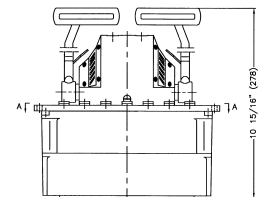

In responding to customer requests, we now offer another electronic control base that works together with various control heads. The basic control head is a model 6555 which is illuminated on either side of the control head. The LED strips indicate the actual running position of the propulsion machinery. This way the operator can match the control handles to the engine speed and direction before taking over the station. In the middle of the control assembly we have a 4 line digital

readout which will provide important information from the propulsion machinery and the control system. A dimmer and a lamp test is provided, the switch (6 shown) can be made to customer requirements. We can provide up to 12 buttons for any shipboard function. This control head is intended for indoor use only. The total assembly, complete, can be ordered under part number 6512. When ordering, please provide your requirements including the control head you would like to use on this base.

6514 CONTROL HEAD

Weight 24 lbs (11 kg)

Intended for multiple shipboard applications, this control head can be used as either a mechanical control, or as an electronic control.

The Kobelt 6514 control head provides redundant electronics and is available with selector switches for application flexibility.

Like all other Kobelt components, the 6514 is constructed entirely of sturdy bronze and stainless steel, ensuring years of corrosion-free service. Available in a polished brass finish, black or white epoxy, or chrome plated - gold plate upon special request. Ask us about other options such as custom designed handles, also available upon request.

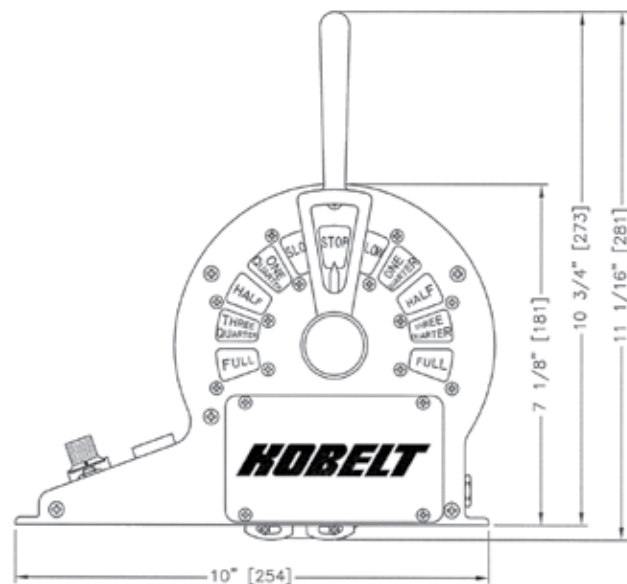
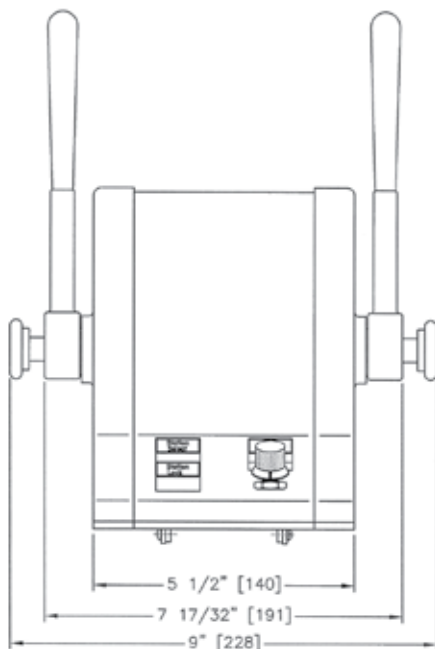

6515 ELECTRONIC TRIPLE CONTROL HEAD

Weight 7 lbs (3 kg)

This control head was designed specifically to handle three independent engines for marine propulsion applications. The 6515 can be mounted separately, or on a control base (shown here mounted on a 6510). It is capable of providing almost any kind of on-board control functions.

The entire unit is constructed in bronze and stainless steel and is water tight from the top side. However, the underside of the unit should be protected from the environment since it is not hermetically sealed. This control head can be used with any other electronic control components provided by Kobelt.



Shown on Model 6510 Control Base

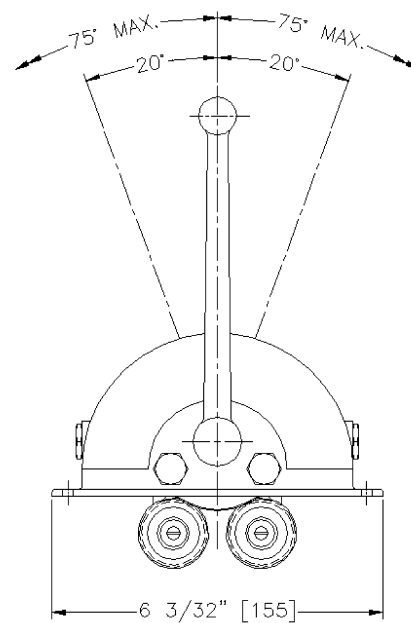
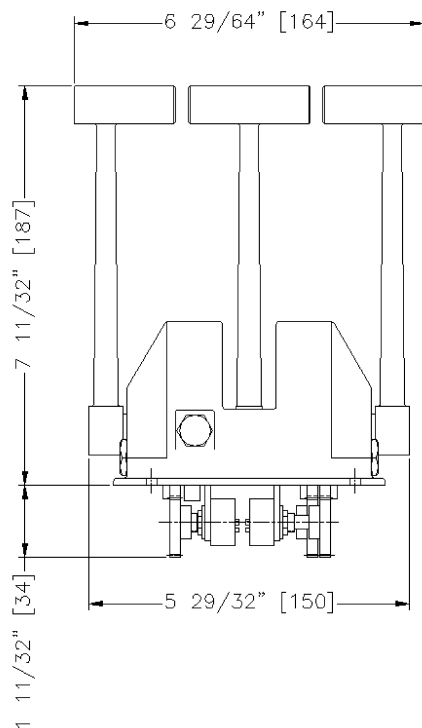

6570 ELECTRONIC CONTROL HEAD

The 6570 is an alternative version of the 6505 / 6505S control head series used in the propulsion control system, and comes with the added feature of a gear feedback indicator showing the gear control position. This unit offers a compact design and the features of a full size control, with the same mounting dimensions as the 6505. This control head is compatible with our 6525 system as well as the Mighty Mariner system.

The handles are used to control the clutch and throttle operation of the engines. Moving the handle forward or backward approximately 15° will engage the clutch in the corresponding position. Moving the handle further will activate the throttle control feature. The feedback indicator will show where the gear is engaged in the desired control position. The source of the feedback must come directly from the gear sensors.

The keypad offers switches for the standard features: Station Select, Station Lock, Throttle Override and Synchronization, and the pad is water resistant, but not recommended for outdoor installation.

The housing and handles are manufactured of bronze and stainless steel with finish options including chrome, black or white epoxy paint and polished bronze.

Ordering Options:

No. Engines: 2 (standard)

No. Potentiometer: 1 per handle

Panel keypad: 4 Switches

Finish: Chrome, Black or

White Epoxy, or Polished Bronze

Handle: Chrome

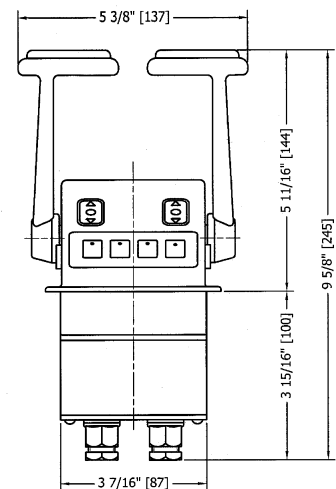
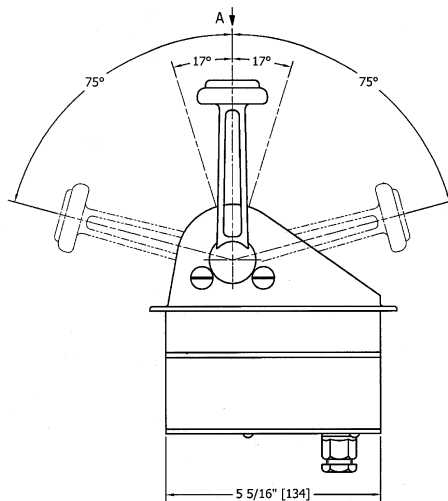

6580 ENGINE CONTROL HEAD (DIAMOND HEAD)

The 6580 Diamond Head Control was developed to add peace of mind while navigating. With its robust design, constructed entirely in bronze and stainless steel, the 6580 Diamond Head is complete with dual handles, membrane switches and simulated RPM and clutch indicators.

This unique control allows you to operate twin engines electronically via the handles, or in back-up mode via the touch membrane switches. The forward, neutral and reverse switches on either side of the control allow you to operate the gear box from neutral to forward or reverse without moving the handles. In order to operate in back-up mode both diamonds must be pushed simultaneously. The (+) and (-) buttons will increase or decrease the engine speed. The centrally located keypad consists of the Station Select, Station Lock, Throttle Override and Engine Synchronization modes of operation.

The rotating 6580R Diamond Head Control was developed to provide the ultimate convenience of having steering and propulsion all in one control. The Full Follow Up steering interfaces perfectly with the Kobelt power steering system.

Both the 6580 and 6580R Diamond Head Controls are compatible with the popular Kobelt Mighty Mariner System.

Note: for twin engine use only, not suitable for exterior applications

Ordering Options:

Finish: Black or White Epoxy

Basic Function or with Back Up

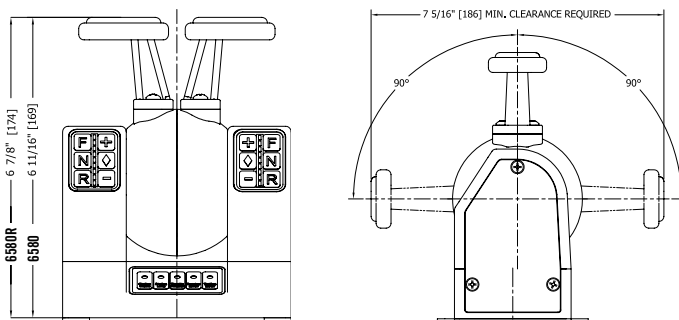

6580



6580R

6652 ELECTRONIC CONTROL HEAD (KRRONOS)

The 6652 Krronos control head was developed to include the latest innovations - LCD touch screen technology is now introduced to the marine industry. With its sleek and compact design, quality construction in bronze and stainless steel and various finish options, the 6652 Krronos Control is complete with a 3.5" LCD touch screen with display and command control functions including: Station Select, Station Lock, Throttle Override, Engine Synchronization, Simulated Engine RPM and Direction Indication, Station-in-command Indication and Alarm functions.

This unit is compatible with the popular Kobelt Mighty Mariner Control System.



Ordering Options:

- S = Single engine application
- T = Twin engine application
- B = Black finish
- C = Chrome finish
- G = Gold Plate
- L = Polished bronze finish
- W = White finish

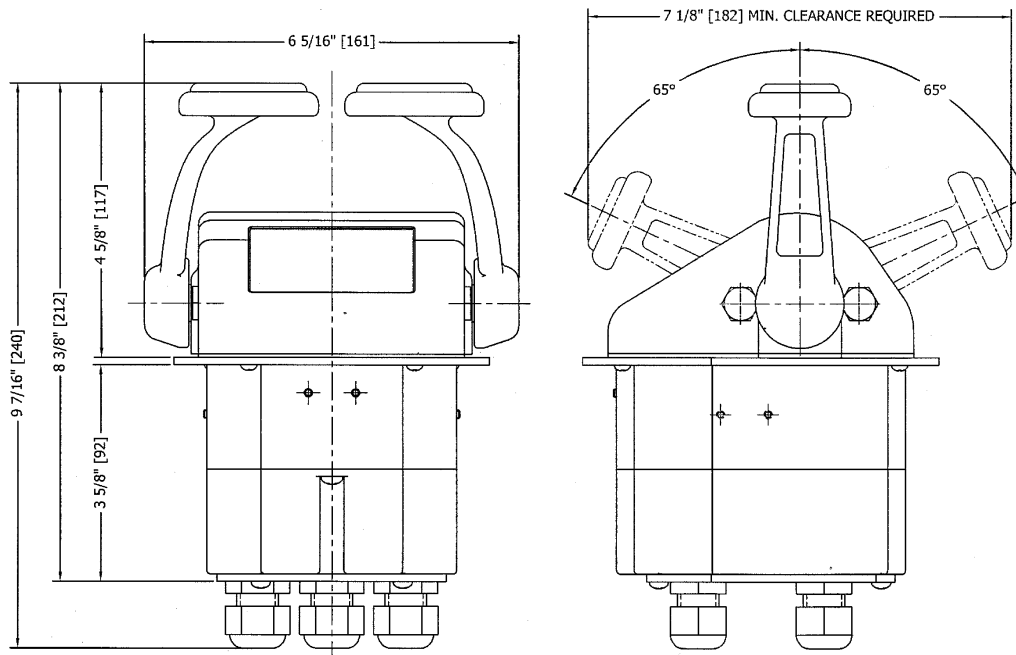

6654 RIGHT ANGLE DRIVE CONTROL FOR 360°

Weight 12 lbs (5.5 kg)

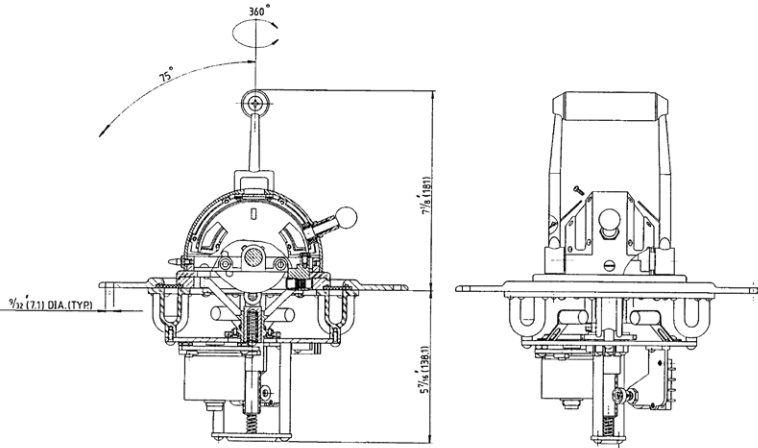

Works exclusively with a 6535 system.



The Model 6654 Control Head was especially designed for 360° right-angle drives to offer carefree control over the disconnect clutch and engine speed. The rugged bronze and stainless steel head is illuminated, can be equipped with a dimmer and is available in various finishes such as chrome-plate and black epoxy. Depending on your needs, Kobelt can supply you with all components, including microprocessors, for a complete turnkey system.

6655 ELECTRONIC CONTROL HEAD

Weight 11 lbs (5 kg)



The Model 6655 is an electronic control head ideal for controlling two main engines and steering gear on virtually any type of vessel 60' or longer. The two chrome-plated handles

have independent, 45° bi-directional movement for precision maneuvering and total control. In addition to controlling engine speed and steering, this head can be used to control waterjets, fixed-pitch gearbox-driven propellers and CP propellers. Depending on your needs, it can also come equipped with a separate panel for station transfer, mode selection or an 8-point alarm system.

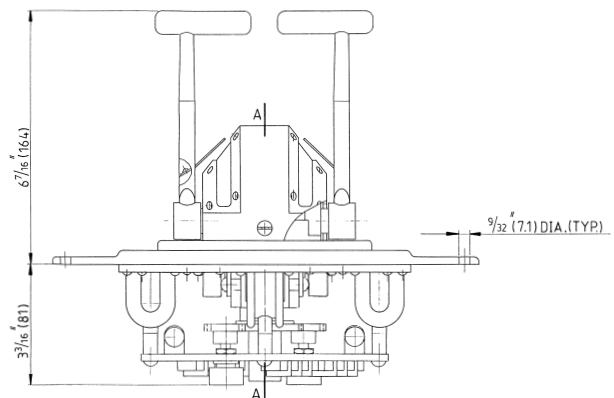

7176 WALK-ABOUT CONTROLLER

This control device is intended to control one or two main engines in a portable "walk-about" style. Much safer than a wireless control, and all the features of a built-in control station.



This unit also provides fingertip control over rudders, and can be equipped with switches or knobs for controlling additional equipment. For example, a jog switch can be used on anchors or thrusters. The small knobs can be used to control proportional bow and stern thrusters.

The 7176 Controller is constructed entirely in bronze and stainless steel and is light in weight. Provision for a shoulder strap has been made so the unit can be worn around the neck like a camera. This unit is completely sealed to prevent water from entering it.

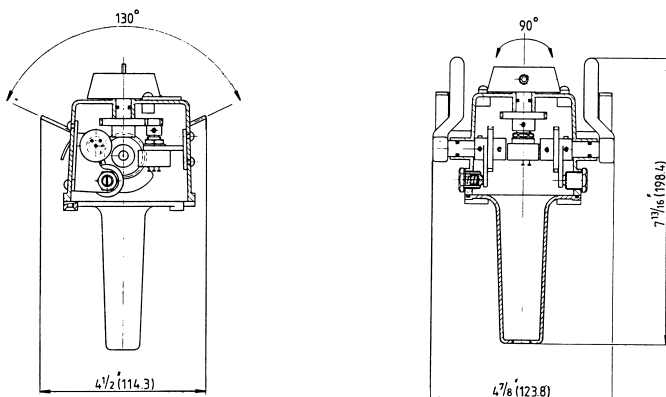

6524 ELECTRONIC ACTUATOR

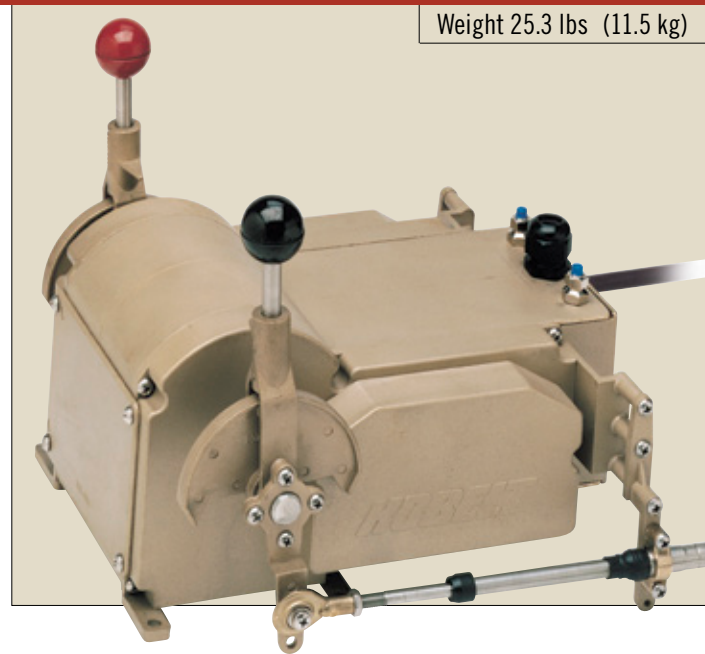
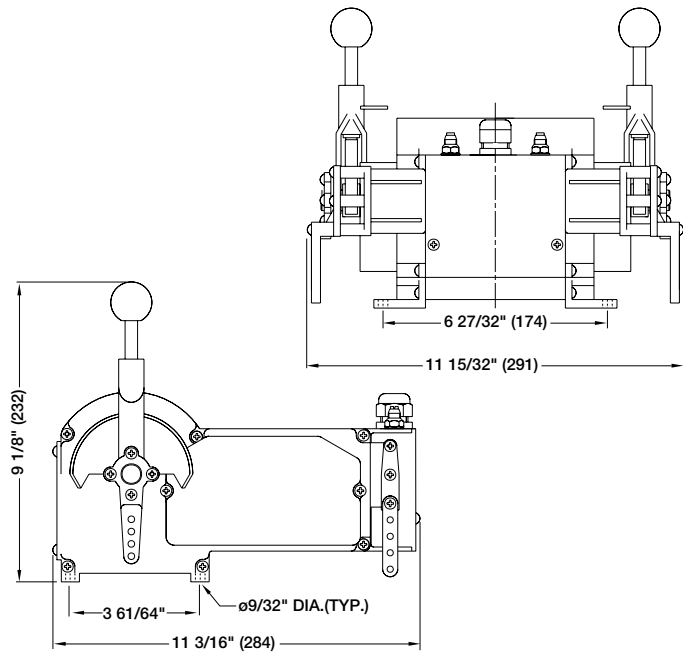

Weight 25.3 lbs (11.5 kg)

This actuator was designed to actuate such items as marine clutches, throttles, trolling valves, controllable pitch propeller mechanisms and various other shipboard & industrial applications. The 6524 has 90 in. lbs. of torque and is equipped with manual disconnect units and an output lever with an internal resilient link to allow the selected systems to be overstroked without damaging the drive train. Due to its revolutionary patent pending design, the entire unit is easy to install and adjust.

6527 ELECTRONIC ACTUATOR

This 6527 electronic actuator is a robust device and is available in different configurations. It is constructed entirely in bronze and stainless steel, except for the motor, worm and potentiometers. It can be used for many marine and industrial applications to operate and position lever-actuated mechanisms.

This unit is similar to the 6527-S, but not interchangeable.

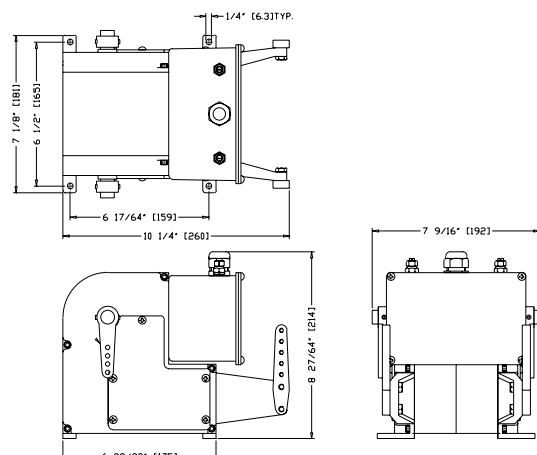

Weight 25.3 lbs (11.5 kg)

The standard unit comes with trim pots, one per side, to limit the lever movement. This unit has a high torque output of 180 in.lbs. This actuator does not have an internal resilient link like our model 6524. Therefore, the stroke must be adjusted precisely to suit the device to be controlled.

6528 ELECTRONIC GENERAL POSITION ACTUATOR

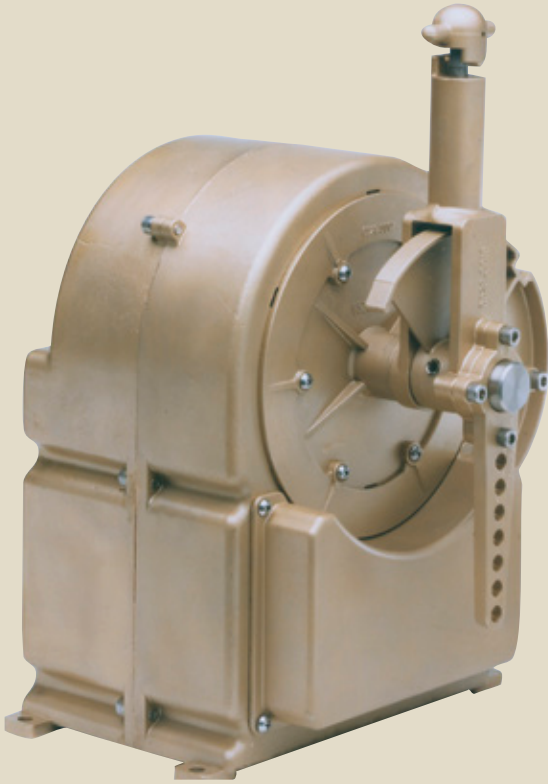

Weight 50 lbs (23 kg)

This actuator was specifically designed to handle heavy duty positioning functions. It has some very unique features not found in any other actuators. First of all, it incorporates a manual override which allows the operator to position the unit manually. Secondly, it has an electro-mechanical clutch arrangement which allows for spring centering or returning the mechanism to a neutral start position in case of power failure. Most importantly, however, the unit has a resilient driven output shaft. This means that when the input shaft (motor driven side) gets ahead of the output shaft, the motor will actually stop and wait until the resilient link has caught up with the input side.

There are three different springs available for the resilient link:
100% spring which produces 600 in. lbs.

75% spring which produces 450 in. lbs.

50% spring which produces 300 in. lbs.

A potentiometer is also provided to give feed back to such things such as pitch indicators, throttles, gear boxes, etc. All the castings and hardware are constructed in bronze and stainless steel.

For items that need accurate positioning, a push pull cable is not recommended, because of the lost motion in push pull cables. A solid rod with rod ball ends is recommended.

Ordering Options	Resilient link Spring
C Clutch	1 100% spring
P Pitch	2 75% spring
T Throttle	3 50% spring
S Spring Return	
B Cable bracket	

6531 ACTUATOR

The 6531 Actuator is capable of handling a wide variety of shipboard and industrial applications. On a ship, it's ideally suited for controlling engine clutches, throttles, CP propellers, trolling valves and any propulsion control function. The output shaft has 90° of rotation and a maximum torque of 150 in.lbs. It comes with either a 12 or 24-Volt DC motor (24-Volt is considered standard), has a reduction gear of 200 to 1 and is equipped with an internal electric disconnect clutch.

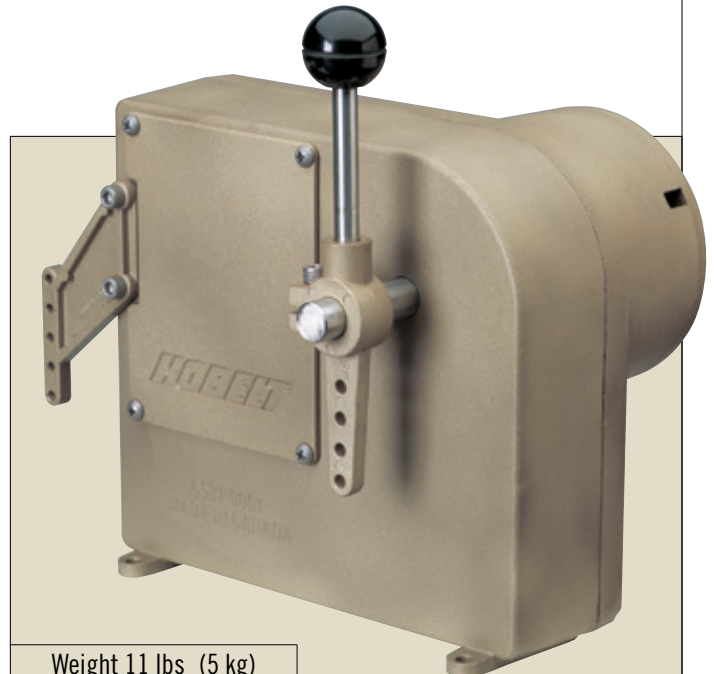
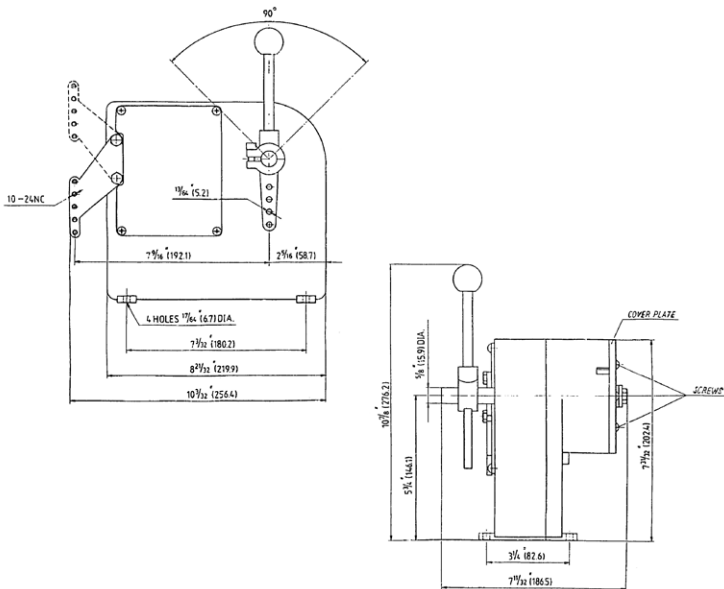

Weight 11 lbs (5 kg)

7165 COMPACT SINGLE AXIS JOY STICK

7167 2-AXIS ELECTRONIC JOYSTICK



This compact joy stick is designed to control positioning devices for either on/off or infinite positioning. This unit is available with either a spring return, or detent, or friction. It is similar to, but smaller than the 7169.

- Ordering Options**
 A Detent
 B Spring Return
 D 1K Potentiometer
 E Terminal Strip
 G Jog switches
 H 5K Potentiometer
 W Friction

Weight 1.0 lbs (0.4kg)



The 7167 Joystick is an excellent all- purpose device for controlling industrial and marine systems. It is especially suited for controlling cranes, winches, propulsion machinery, steering gear and bow thrusters.

Weight 4 lbs (1.8kg)

7169 MULTIPURPOSE ELECTRO CONTROLLER

7170 JOG LEVER



Weight 2.2 lbs (1kg)

This unit is ideally suited for many marine and industrial applications such as bow thruster, steering gear and winch control. It is also an excellent system for controlling hydraulic servo devices and even C.P. propulsion and throttle controls.

Ordering Options

- | | |
|--------------------|-----------------------|
| A Detent | E Terminal Strip |
| B Spring Return | F Two Switches |
| C Switch | G Jog Switches Option |
| D 1K Potentiometer | H 5K Potentiometer |

Please state resistance in Ohms and rotation of potentiometer in degrees when ordering.



Weight 2.2 lbs (1 kg)

Constructed from bronze and stainless steel, The Kobelt 7170 Jog Lever is both durable and watertight. Various finishes are available and the unit can be ordered with the cable running straight out or down.

Ordering Information

- | | |
|--------------------------------------|--------------------------------|
| A - Black epoxy base with chrome hub | D - All polished bronze |
| B - All black epoxy | 1 - Cable leading straight out |
| C - All chrome | 2 - Cable leading down |

7171 FULL FOLLOW-UP CONTROL LEVER

Weight 7.5 lbs (3.4 kg)



The Model 7171 Control Lever is a full follow-up rudder control equipped with a detent in the mid-handle position. The 7171 is manufactured in bronze and stainless steel and, because of its watertight nature, can be installed anywhere on the ship.

The 7171 is available with 2 Microswitches (1 per side), 2 Potentiometers and 2 Trim Pots. The 7171 is also available as a Jog Lever with 2 Microswitches per side.

Ordering Information

A 2 switches and 1 potentiometer G 4 Switches
B 2 switches and 2 potentiometers P 1 potentiometers

Please state resistance in Ohms when ordering. A trim pot will be supplied with each potentiometer.

7171SW FULL FOLLOW-UP CONTROL LEVER

Weight 11 lbs (5 kg)



Like the Model 7171, the 7171-SW Control Lever is a full follow-up rudder control. Unlike the 7171 however, the SW can be used as a main electronic control station and is ideally suited for high-speed craft such as catamarans. As with all Kobelt electronic components, it can come with both a rudder demand and a rudder control.

Ordering Information

A 2 switches and 1 potentiometer
B 2 switches and 2 potentiometers
P 1 potentiometers

Regular potentiometer supplied with this unit is a 1K.

7172 ELECTRONIC HELM

Weight 22 lbs (10 kg)

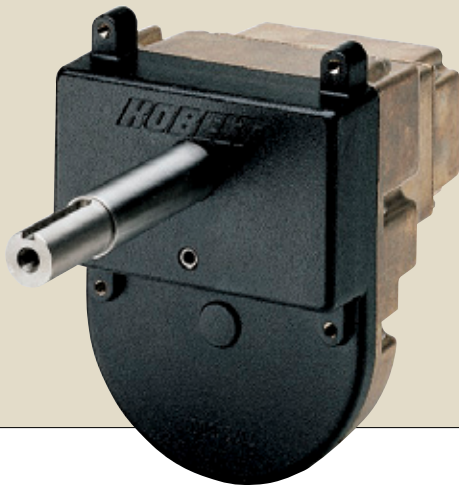

The Electronic Helm sends a signal to the steering gear which, in turn, accurately controls the rudder. It comes with 1, 2 or 3 potentiometers and is available with one, two and three turns from hardover to hardover. Heavy duty construction allows helmsmen to wrestle the wheel in the roughest of weather without any risk of damage.

7173-K ELECTRONIC FULL FOLLOW-UP AMPLIFIER

Weight 5.5 lbs (2.5 kg)



The 7173 is designed to accept the command signal from each of our seven electronic helm control models. It is ideal in catamarans to synchronize two rudders without a tie bar and can also be used to control mechanically linked rudders with either single or dual speed. The 7173-KFFU incorporates the latest in electronic technology, is easy to adjust, and a breeze to install anywhere onboard ship.

7168 RUDDER ANGLE FEEDBACK UNIT

Weight 2.2 lbs (1 kg)



The Model 7168 relays rudder angle positions to an autopilot, angle indicator or to electronic steering components. This smaller version of a rudder angle feedback unit is available with one or two potentiometers. Its compact design and watertight construction allows it to be installed in tight quarters inside or outside the ship.

Ordering Information

7168-P - 1 potentiometer
 7168-PP - 2 potentiometers
 Standard Potentiometers are 1 K.
 3 Pillars also available

7174 RUDDER ANGLE FEEDBACK

Weight 6.6 lbs (3 kg)



This unit is designed to be connected to the rudder stock and to feed back the rudder angle position to the Auto Pilot, Full Follow Up control systems and Rudder Angle indicator. The 7174 is available with up to 3 Potentiometers, 3 Trim Pots and 4 Microswitches.

Ordering Information

A. 2 switches and 1 potentiometer	E. 2 trim pots
B. 2 switches and 2 potentiometer	F. 3 trim pots
C. 2 switches and 3 potentiometer	G. 4 switches
D. 1 trim pot	

7175 RUDDER INDICATOR

Weight .7 lbs (.3 kg)

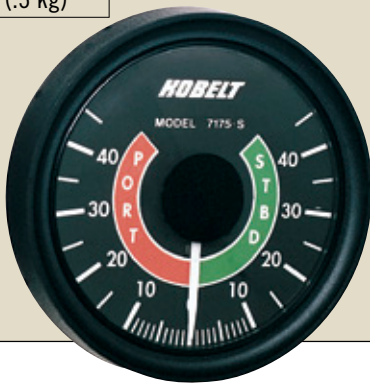

The 7175 rudder indicator system is designed to continuously monitor and indicate the position of your rudder. Whether you are maneuvering, power steering or changing course, an accurate readout of the rudder position is displayed on a three colour, three inch display. The basic system consists of a 7175-M Master Station, and a Kobelt 7168 or 7174 feed back unit.

Up to six additional "repeater stations" can be installed by using the 7175-S repeater.

Both the master and repeater have a backlit, waterproof translucent display.

7178 PANORAMIC RUDDER ANGLE INDICATOR

Weight 13.2 lbs (6 kg)



This bronze and stainless steel unit was especially designed so you can see the designated rudder position signal from all areas within the wheelhouse. Access to the 30,000 hour light bulb is easy through a removable plate in the base. The unit is available in either 12 or 24-Volt DC and comes with a manual dimmer.

Ordering Information

7178-DC12	12 Volt
7178-DC24	24 Volt

7143 NON-DRAIN BACK VALVE

This valve is intended to be used in power steering systems.

Its purpose is to retain all of the hydraulic fluid in the steering system itself when the power-driven hydraulic pumps are not operational, to allow the use of the helm pump without loss of hydraulic fluid. Capacity: 15 GPM, 1500 PSI Maximum.

7143 requires a minimum pressure of 200 psi at all times. Pressure line connections are 3/4" O-ring. Return line connections are 1-1/16" O-ring.



Weight 3.3 lbs (1.5 kg)

7144 SINGLE SOLENOID ADAPTER BASE

The 7144 is designed to provide control for the rudder in either direction. Its maximum flow capacity is six gallons per minute and can be equipped with either an open or a closed centre solenoid valve. The 7144 is equipped with a flow control to provide an adjustable speed for rudder positioning.

Ordering Information

7144 Without solenoid	
7144-DC12	With 12 volt solenoid
7144-DC24	With 24 volt solenoid
7144-DC32	With 32 volt solenoid
7144-AC110	With 110 volt AC solenoid

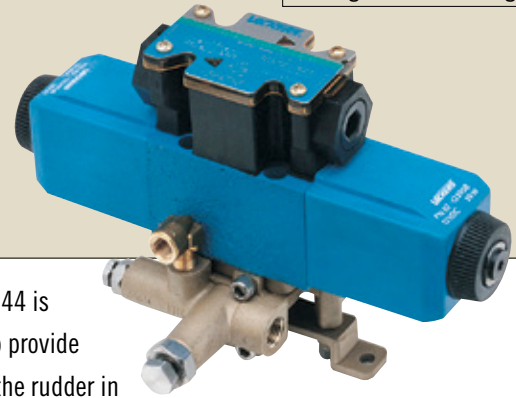

Weight 6.6 lbs (3 kg)

7145 DUAL SOLENOID ADAPTER BASE

The 7145 is designed for steering systems that require more than one rudder speed. Its state-of-the-art design allows for two or three speed operations and an auto-fill line in the header tank. Maximum flow capacity 12 gallons.

Ordering Information

7145 Without solenoid	
7145-DC12	With 12 volt solenoid
7145-DC24	With 24 volt solenoid
7145-DC32	With 32 volt solenoid
7145-AC110	With 110 volt AC solenoid

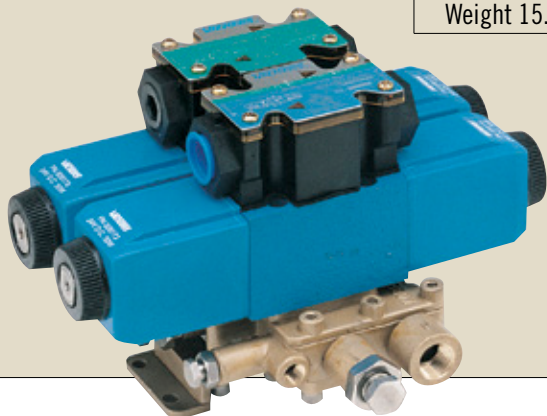

Weight 15.4 lbs (7 kg)

7148 FULL POWER FOLLOW-UP

The Model 7148 is Full Power Follow-Up unit that provides "Servo Power Steering", similar to the power steering found in cars and trucks. Whether it's installed in a workboat or a large pleasure craft, this unit allows for absolute control and fingertip rudder operation. Its solenoid can be used for either auto pilot or jog lever remote control and has a feature allowing automatic switch to manual steering.

Ordering Information

7148 Without solenoid	
7148	120 AC with 120 VAC solenoid
7148	12 DC with 12 DVC solenoid
7148	24 DC with 25 DVC solenoid
7148	32 DC with 32 DVC solenoid

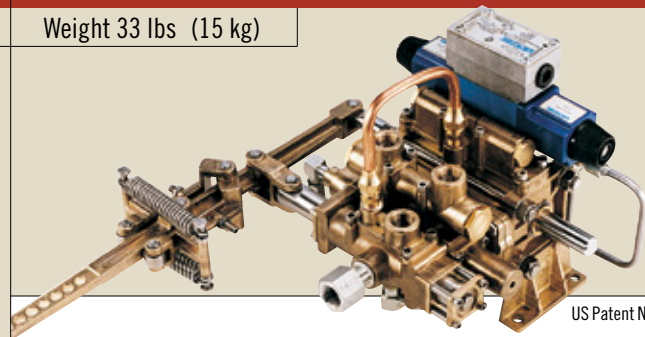

US Patent No. 4375771

Weight 33 lbs (15 kg)

KOBELT HELM PUMPS

5 Models Available

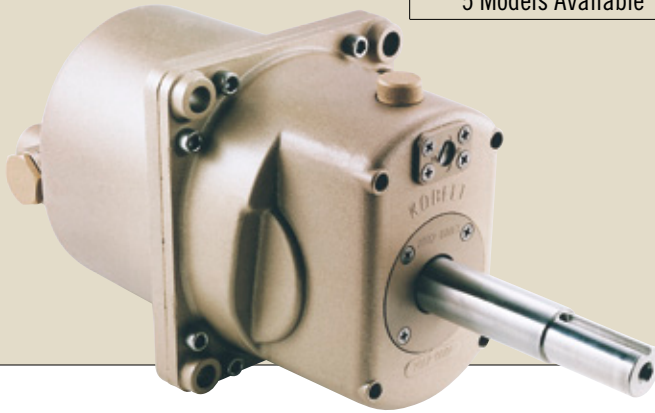

Kobelt manufactures five different helm pumps, all of which incorporate lock valves, filler plugs and interconnecting plugs for multi-station applications. An external adjustment screw, available on three of our helm pumps, is designed to face the operator for easy access.

7201 AUTOPILOT PUMP RELAY

Weight 15 lbs (6.8 kg)

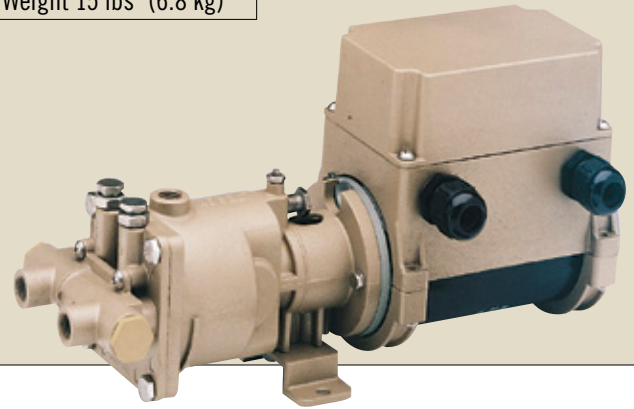

Available with an in-house PC board, the 7201 has relays that are capable of handling 30 amp current for either rotation with a 12 volt motor or, 15 amps with a 24 volt motor. A fuse is provided for maximum load on both motors. With motor leads internal in the housing, the centre block is for the directional control circuit, while the other blocks are for power in and out to the motor.

Ordering Information

7201-pr12 (12 volt)

7201-pr24 (24 volt)

Please specify 12 or 24 volt

STEERING CYLINDERS

20 Models Available

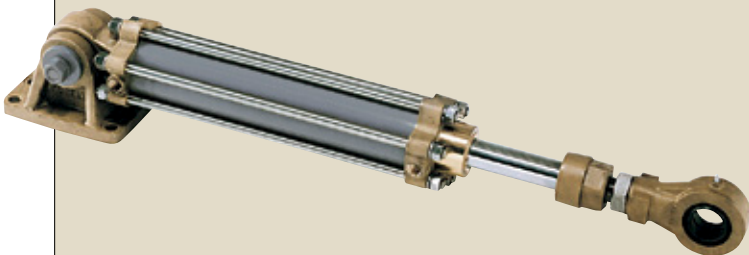

Kobelt manufactures hydraulic steering gear components that offer rudder torques from 600 footpounds (90 kg/meter) to up to 1,200,000 footpounds (160,000 ton/meter).

From Outboard to Ocean-going, cylinders range in diameters from 1-1/4" up to 10" I.D. with various strokes.

Lloyd's
Register



7147 FULL POWER FOLLOW-UP STEERING CYLINDER

Weight 33 lbs (15 kg)

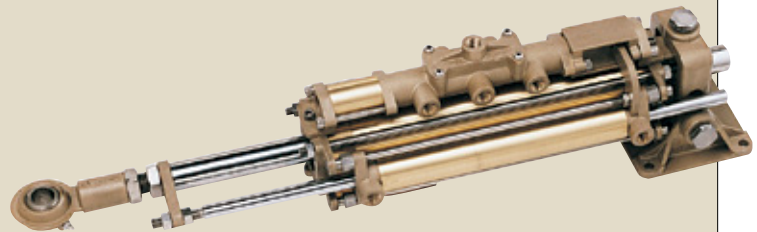

US Patent No. 5289756

This hydraulic servo steering system is designed for workboats up to 80' and pleasure boats up to 120' in length. The full power follow-up valve and servo incorporated into the existing cylinder eliminates the need for any steering linkage. Helmsmen can operate the rudder effortlessly and with complete control. For larger sizes, up to 5 ton meter, ask about Kobelt model 7085.

ELECTRONIC ALARM PANELS



6511-APE10

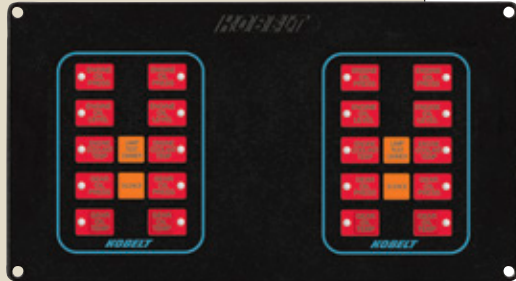

6511-APE10



6511-AP8-S

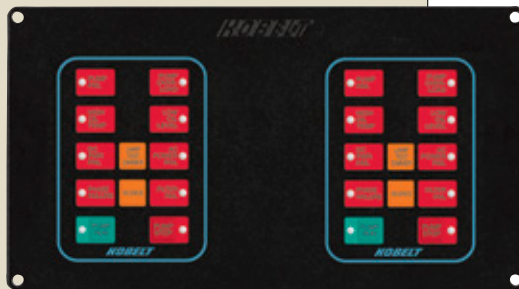

6511-AP8-T



6511-SP

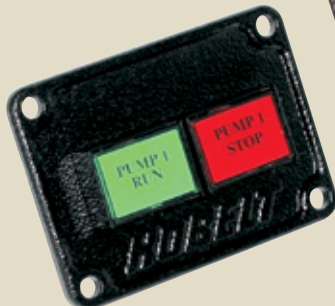
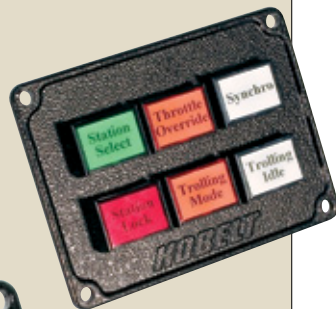

Kobel supplies a family of alarm and communication panels for a consistent, contemporary look, available in various configurations designed to monitor almost all functions. All systems are microprocessor-based and use the latest technology for maximum versatility.

Engine alarm systems are available for one or two station twin engine applications. Wheelhouse start/stop alarm panels are available for hydraulic power packs fitted with single pump or dual pump arrangements.

Standard panel size is 6.5" x 11.5" with an underside protected housing depth between 3" and 8". Units are constructed from bronze with powder coated face for maximum corrosion resistance, durability and good looks.

Standard features include Sonalert and dimmer switch.

Major Alarm Points:

- System oil pressure
- Low oil level
- High oil temperature
- Pump motor overload
- AC, DC, or Phase failure
- Oil filter failure

Small Switch Panels

Mainly used for station selection, but can be used for any application requiring switching or indicators of this nature. Panels are available in several sizes and switch/lamp arrangements:

- Water proof and non-waterproof switch/lamp versions are available
- 1 to 6 switches or lamps

These panels are manufactured from bronze and are powder coated for maximum durability and a pleasing appearance.

STARTER PANELS

Kobel Manufacturing is also capable of providing Starter Panels for single and multi Power Packs as well as remote start and stop panels for the wheelhouse or the engine control room. These units are individually made to customer requirements and are all made to meet classification standards (i.e. ABS or Lloyds).

The Starter Panel (at right) is for a dual pumping system, providing all the necessary breakers and safety devices to comply with the inspection authorities. As well as the transfer of the control from the steering compartment to the engine control room and wheelhouse.



6511-AP8-S



ENGINE TELEGRAPHS

KOBELT offers telegraph systems that allow for trouble-free communication between the wheelhouse and engine room. Units are available in both single and twin engine configurations.



6511-TP Dual



6511-TP

SYSTEM DRAWINGS

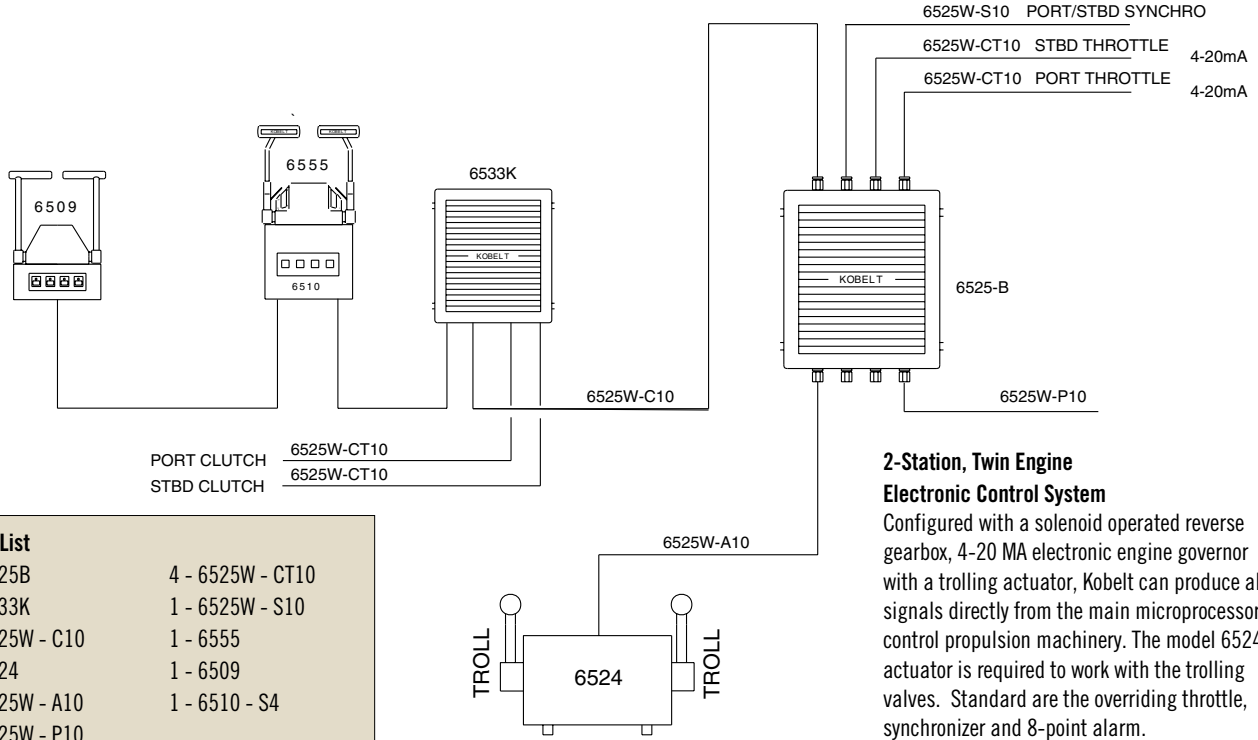

2-Station, Twin Engine Electronic Control System

Configured with a solenoid operated reverse gearbox, 4-20 MA electronic engine governor with a trolling actuator, Kobelt can produce all signals directly from the main microprocessor to control propulsion machinery. The model 6524 actuator is required to work with the trolling valves. Standard are the overriding throttle, synchronizer and 8-point alarm.

Parts List

1 - 6525B	4 - 6525W - CT10
1 - 6533K	1 - 6525W - S10
1 - 6525W - C10	1 - 6555
1 - 6524	1 - 6509
1 - 6525W - A10	1 - 6510 - S4
1 - 6525W - P10	

3-Station, Twin Engine Electronic Control System

For use with hydraulically actuated clutches, mechanical governors and trolling valves.

Place the trolling valve in lock position for normal running to actuate the engine from idle to full speed. Lock throttles in idle or near idle position when selecting trolling mode. Slip will increase and decrease off the trolling valve proportionately when the control head is operated in the throttle range and the actuators will go to maximum position. Damage to the gearboxes is prevented when trolling is done at low RPM.

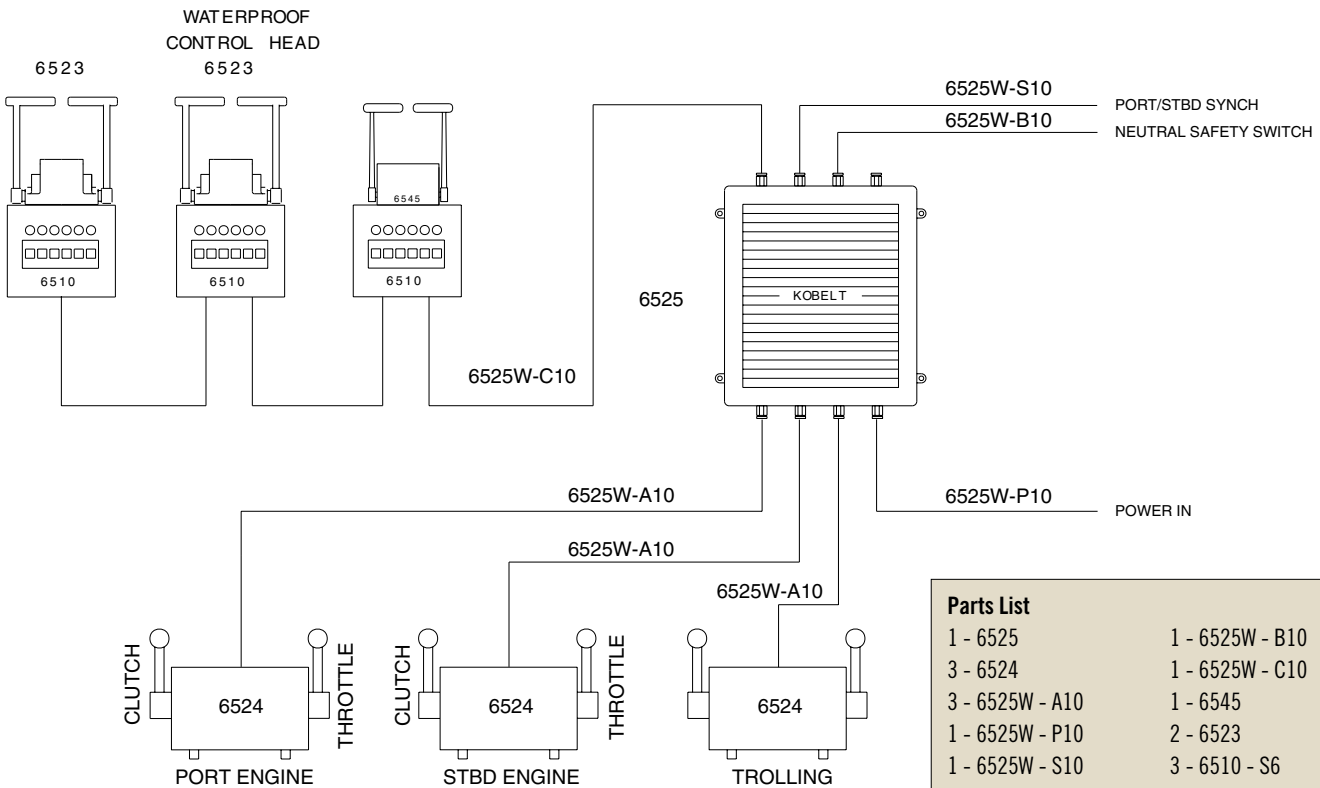

Parts List

1 - 6525	1 - 6525W - B10
3 - 6524	1 - 6525W - C10
3 - 6525W - A10	1 - 6545
1 - 6525W - P10	2 - 6523
1 - 6525W - S10	3 - 6510 - S6

SYSTEM DRAWINGS

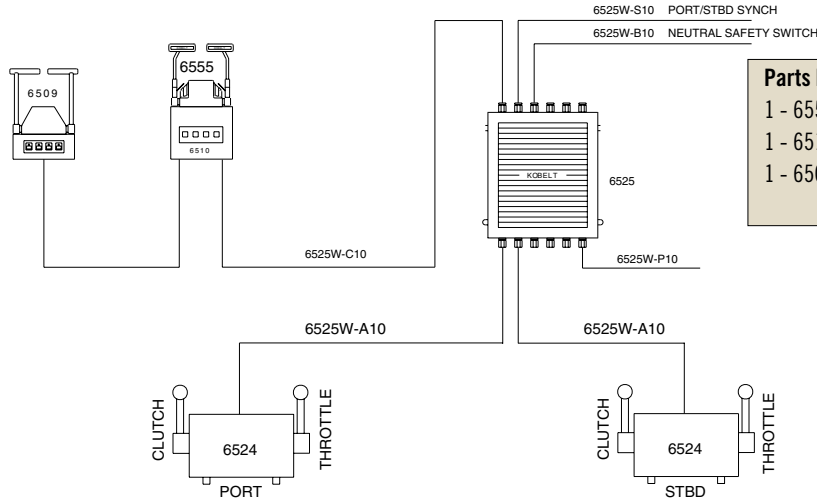

Parts List

1 - 6555	1 - 6525	1 - 6525W - C10
1 - 6510 - S4	2 - 6524	1 - 6525W - P10
1 - 6509	1 - 6525W - B10	1 - 6525W - S10
	2 - 6525W - A10	

Twin-Engine, 2 station, electronic Control System

Working with 2 hydraulically actuated reverse gearboxes and 2 mechanical governors operated by actuators, magnetic pickups are connected to the microprocessor by two synchronize wires. The engine is synchronized when this information is fed into the microprocessor. All Kobelt control systems work with the synchronizer.

Single Engine, 3-Station, Electronic Control System

Working with a hydraulically actuated gearbox and regular mechanical engine governor, interconnecting cables between the microprocessor and the actuators can be cut to client's specific lengths. Please refer to the number of the required cable shown in the drawing. Cables are available in standard 30' lengths and attach to the main microprocessor 6525. Terminal strips attach cables to the actuators.

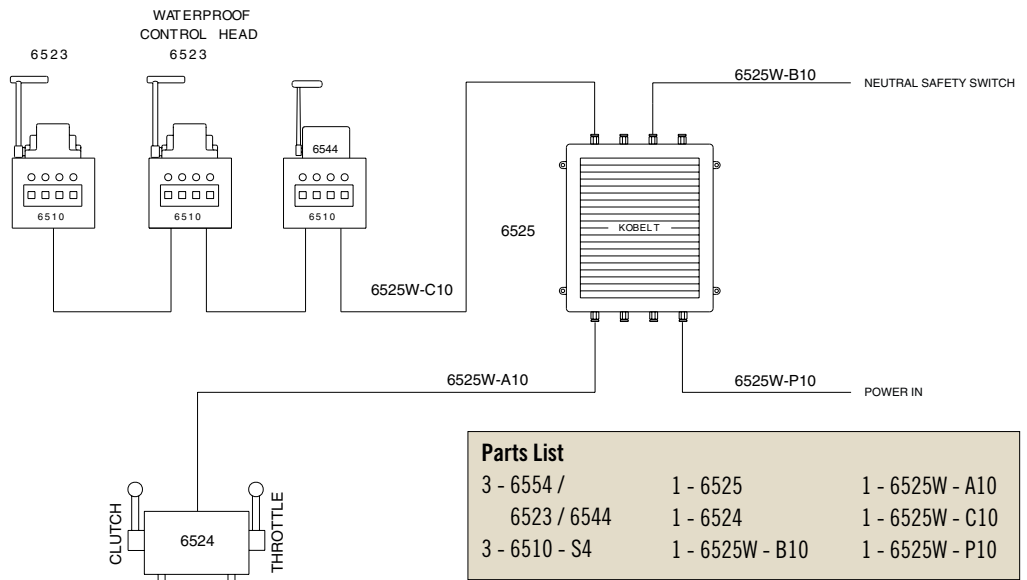

Parts List

3 - 6554 / 6523 / 6544	1 - 6525	1 - 6525W - A10
3 - 6510 - S4	1 - 6524	1 - 6525W - C10
	1 - 6525W - B10	1 - 6525W - P10

Twin Engine, 2-Station Pitch and Throttle Control System

Supplied with actuators for both pitch and throttle, synchronizers and overload protection, this system is capable of providing disconnect clutches between engine output and propeller shaft drive plus engine speed interlocks.

Generally, single lever pitch and throttle controls are provided. The 2 handle system, as illustrated, allows separate control over pitch and throttle. Pitch is increased in either direction and the engine is accelerated proportionately.

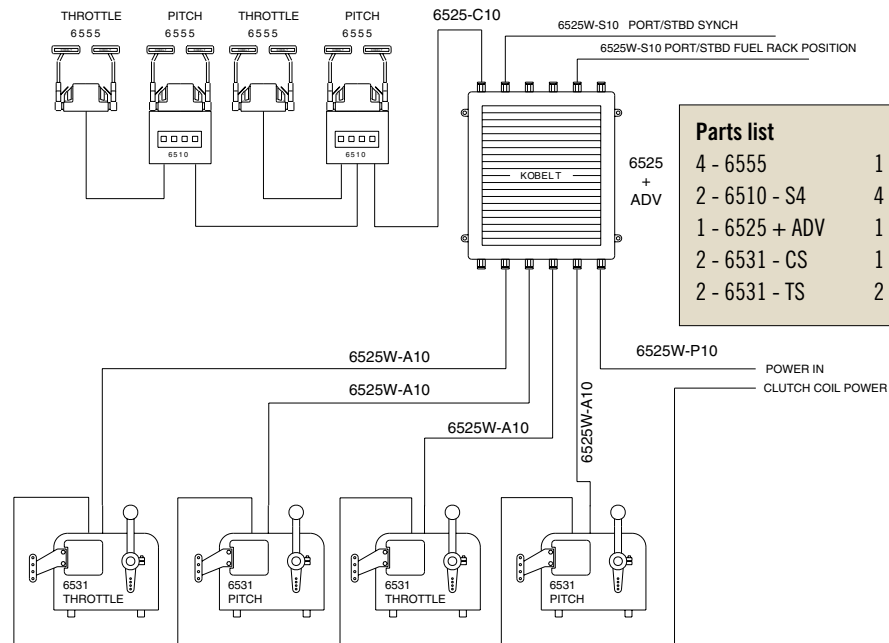

Parts list

4 - 6555	1 - 6525W - B10
2 - 6510 - S4	4 - 6525W - A10
1 - 6525 + ADV	1 - 6525W - C10
2 - 6531 - CS	1 - 6525W - P10
2 - 6531 - TS	2 - 6525W - S10

KOBELT DISC BRAKES

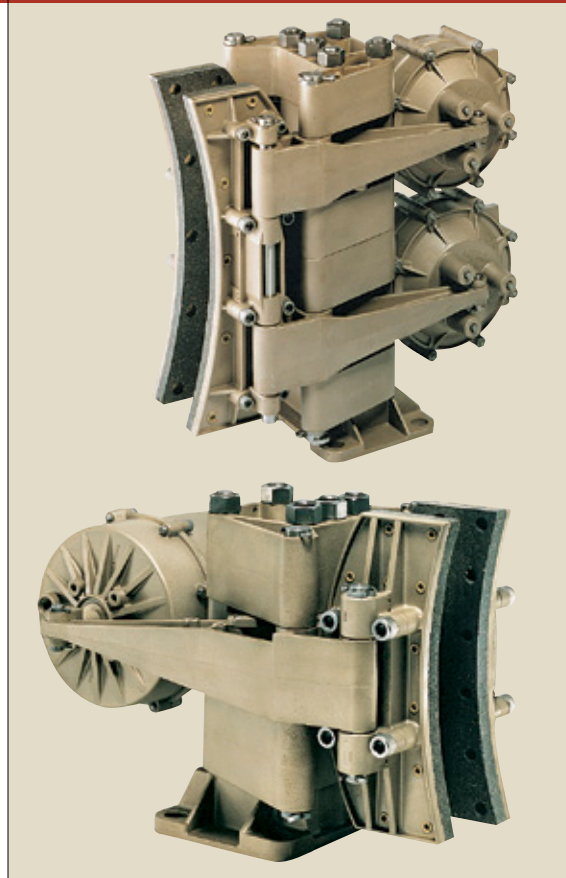

Kobelt Disc Brakes can be found around the world in everything from supply vessels and pipe laying barges to conveyor belt systems, chair lifts, cable spooling reels and wind generators. Our disc brakes are so versatile and rugged, they're also used extensively in industries such as mining, paper-making and aerospace.

In addition to disc brakes, we also offer bronze and steel brake calipers, brake linings and brake discs. Kobelt discs are available in solid steel, ventilated, segmented, and internally water-cooled.

Extensive research and innovative design has enabled us to patent many of the unique features found in our brake systems.

Kobelt's disc brakes are currently manufactured under one or more of the following patents. Further patents are pending.

U.S. Patent Numbers:	Canadian Patent Numbers:
3722636	895693
3815471	922603
4013148	1069066
4060153	1072025
4108285	1158181
4121697	1176187
4164993	
4236608	
4393962	
4572335	

KOBELT PNEUMATIC CONTROLS

Whether your vessel is 60 or 600 feet in length, there's a Kobelt pneumatic control system to suit your needs. With a pneumatic system you can have any number of control stations, plus the option of adding additional ones without affecting performance. Regardless of the distance or the force required, the control heads can be moved smoothly and effortlessly.

We also offer propulsion timing packages that come with or without shaft brakes. A timing system fulfills three very important purposes:

1. it protects your propulsion equipment;
2. it ensures that the gear box is engaged before you accelerate your engine; and
3. it allows you to go from full ahead to full astern without damaging your gear box or stalling your engine.

Components for all our pneumatic control and timing systems are manufactured to the highest specifications using state-of-the-art technology and the finest materials.

Kobelt's pneumatic controls are manufactured under one or more of the following patent numbers.

U.S. Patent Numbers:	Canadian Patent Numbers:
3455186	828507
3724970	922594
3766835	923767
3783742	928607
3795110	932600
3820438	936055
3826490	939202
3838630	947619
3900090	964138
	964555

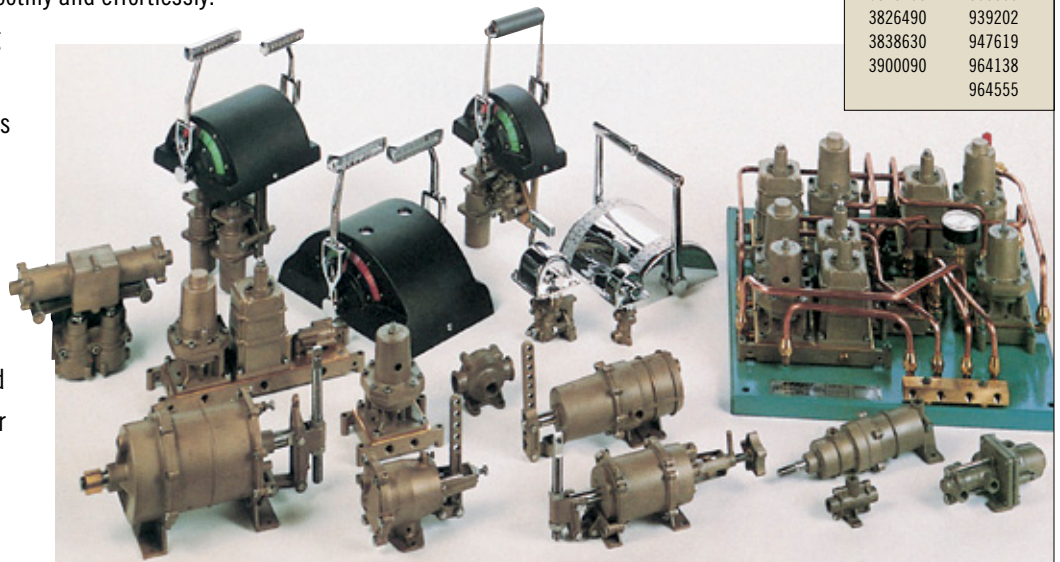

KOBELT PUSH-PULL CONTROLS

For lasting quality and rugged good looks, nothing compares to Kobelt small craft push-pull controls. Their componentry is made entirely out of brass and stainless steel and, thanks to flexible cables and no intermediate supports, they're a breeze to install. And not only do they look good, they come with a very attractive price tag too!

Kobelt push-pull controls are the most price effective and reliable controls on the market today. Outlasting any other product on the market by a ratio of 2:1, it is understandable why boaters will choose this product over less expensive units.



Kobelt's push-pull controls are manufactured under one or more of the following patent numbers. Further patents are pending.

U.S. Patent Numbers:	Canadian Patent Numbers:
4280371	1153673
4326612	1158136
4453428	
4470492	





Kobelt Manufacturing, Surrey, British Columbia, Canada

At Kobelt, we stress the importance of quality, precision, competitive pricing and prompt delivery. Our team of dedicated production staff is uncompromising in ensuring that we meet the needs of all our valued customers. Our growing reputation in world markets is proof of our commitment to highest possible standards.



All Kobelt electronic equipment comes with a 2-year limited warranty that is the best in the industry. Strict quality control manufacturing and sturdy corrosion-resistant materials ensure trouble-free service above and beyond this generous warranty period.

KOBELT



BRAKES, HYDRAULICS, MECHANICAL, ELECTRIC

www.mgdis.net

+1 416 414 8054

sales@mgdis.net

5M 03/12

PRINTED IN CANADA